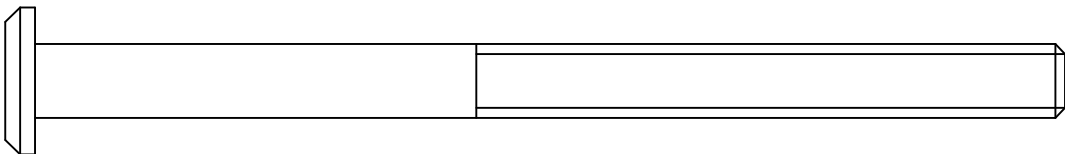
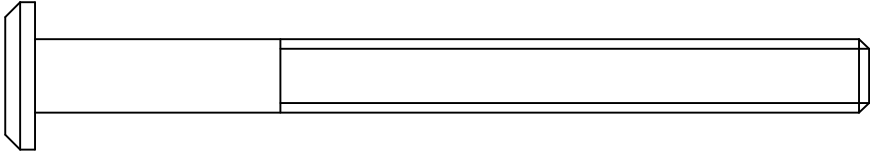
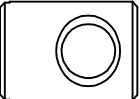
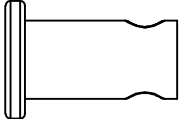
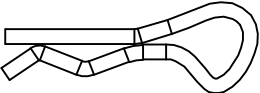
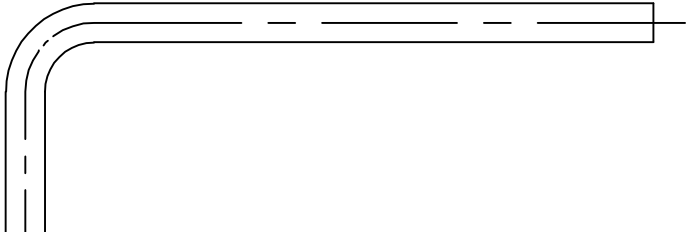
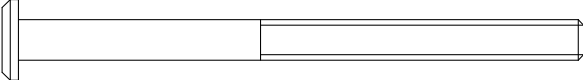

- 1  **x 4** M6 x 105mm
- 2  **x 4** M6 x 85mm
- 3  **x 4** M6 x 14mm
- 4  **x 2** $\varnothing 8$ x 13mm
- 5  **x 2**
- 6  **x 1**

1

MEDISANA®

1  x 4 M6 x 105mm

3  x 4 M6 x 14mm

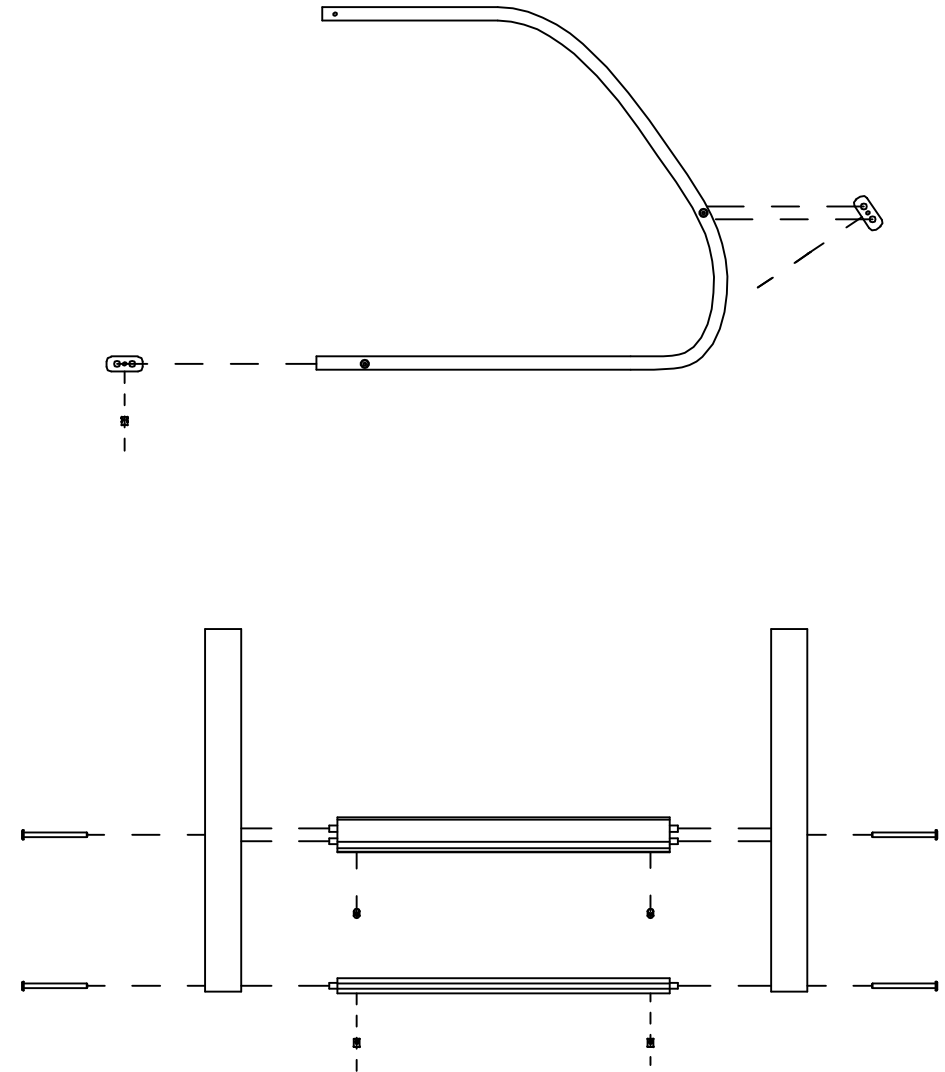
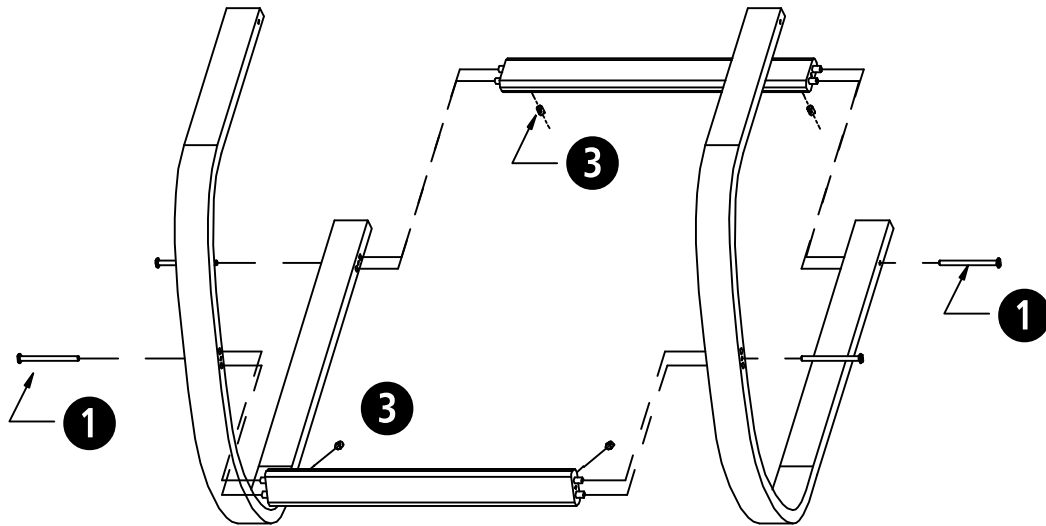

MEDISANA®

4

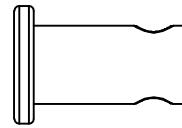

x 2 ø8 x 13mm

2

5

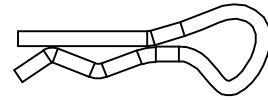

x 2

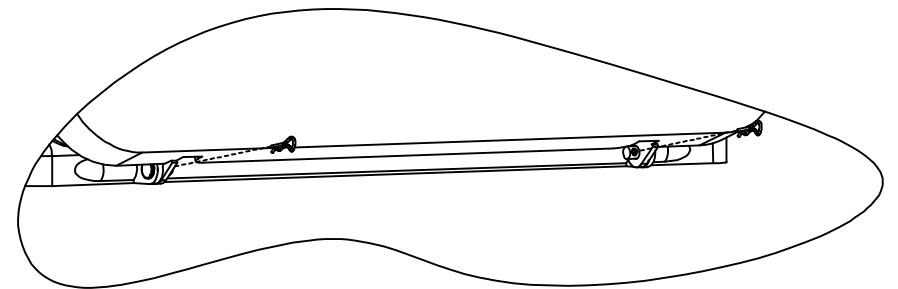
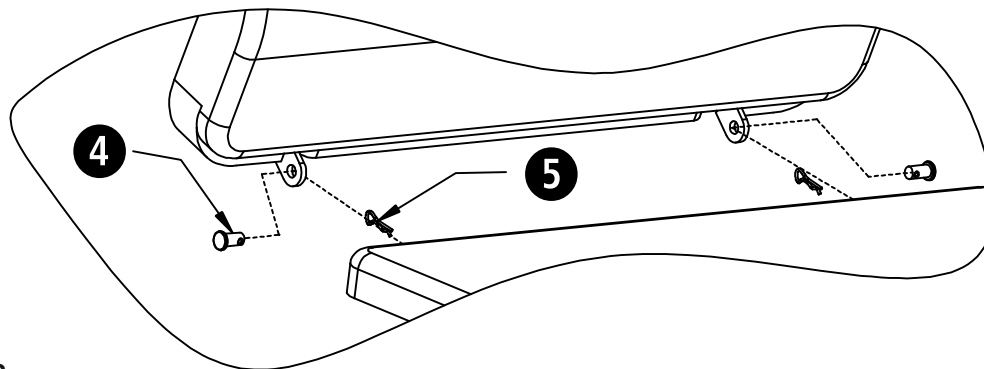
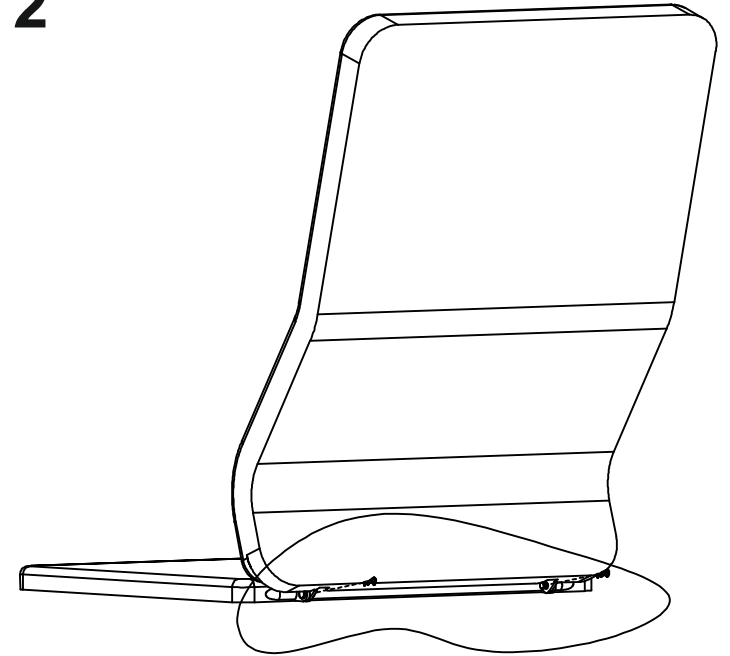
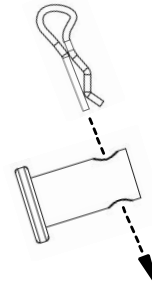
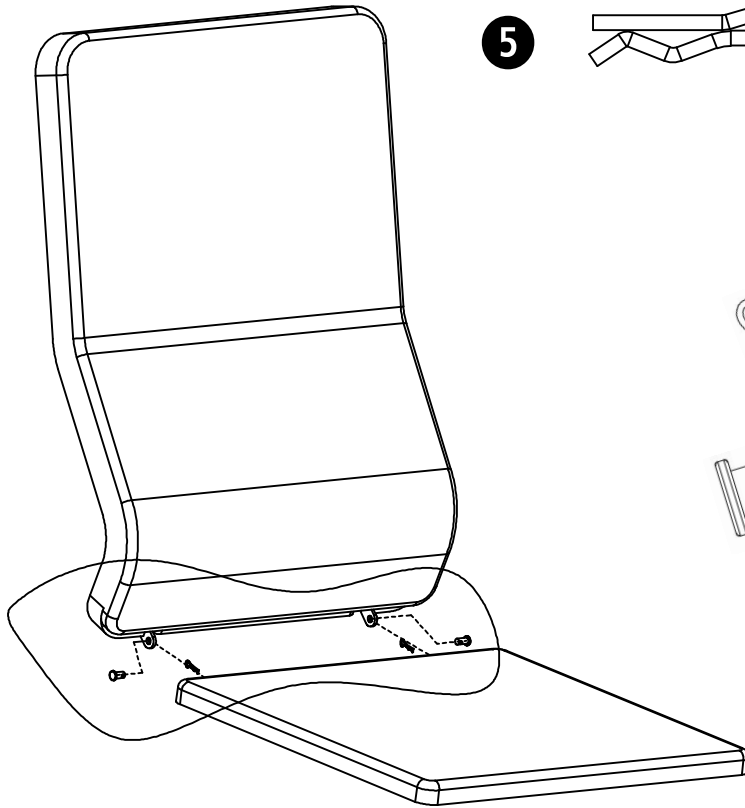

3

2

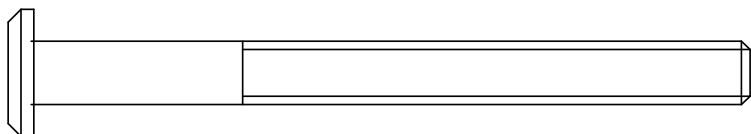

x 4

M6 x 85mm

MEDISANA®



Neigung der Rückenlehne auswählen (A oder B)

Choose backrest angle (A or B)

Choisissez l'angle du dossier (A ou B)

Elija el ángulo del respaldo (A o B)

Kies de hellingshoek van uw rugleuning (A of B)

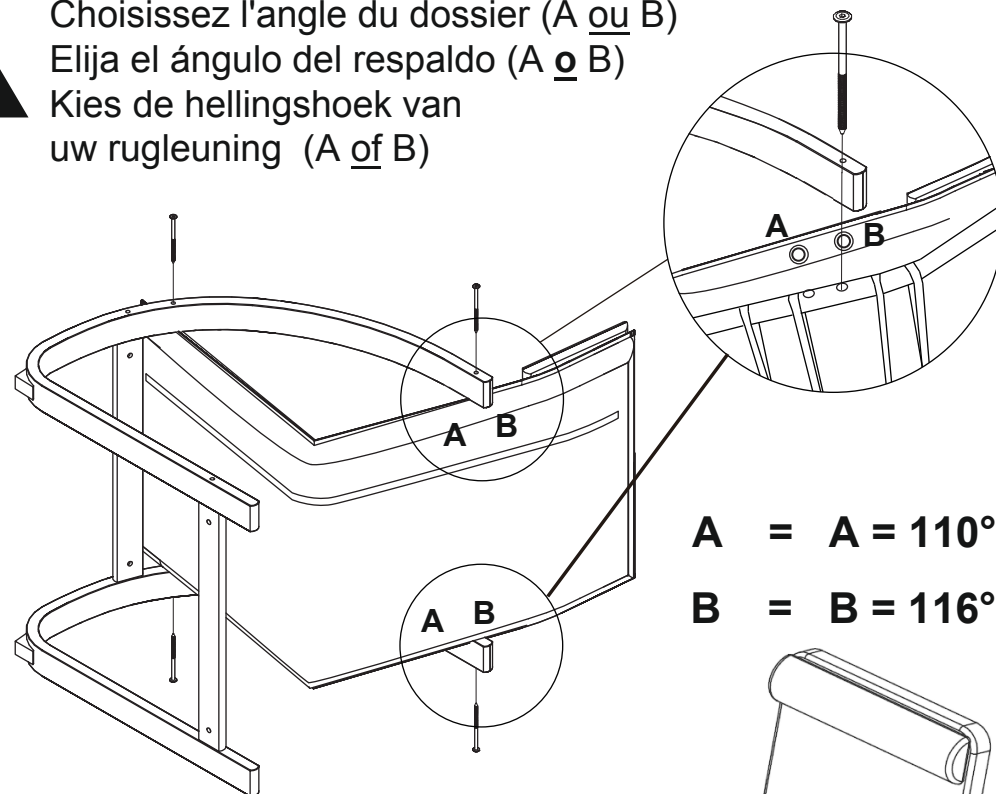
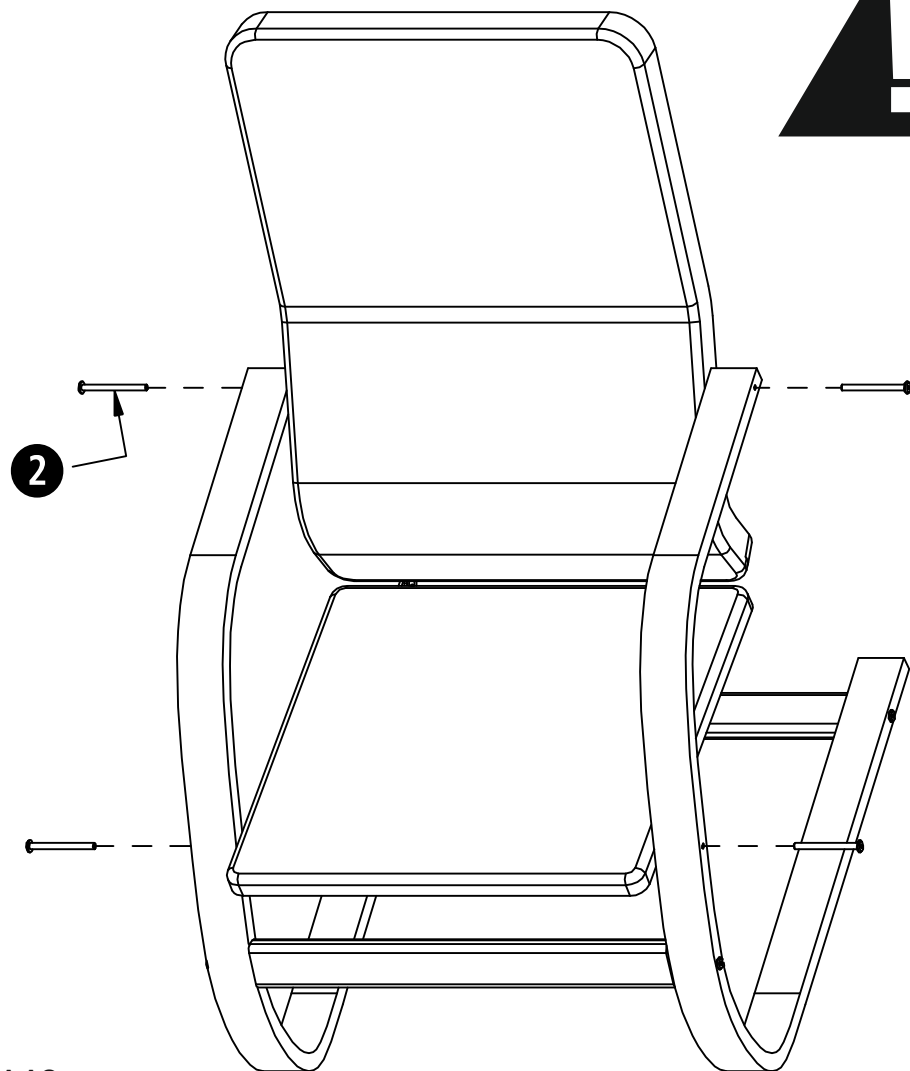

A = A = 110°

B = B = 116°

Επιλέξτε ρύθμιση κλίσης πλάτης (A ή B)
Выбор наклона спинки (A или B)

