

ASSEMBLY

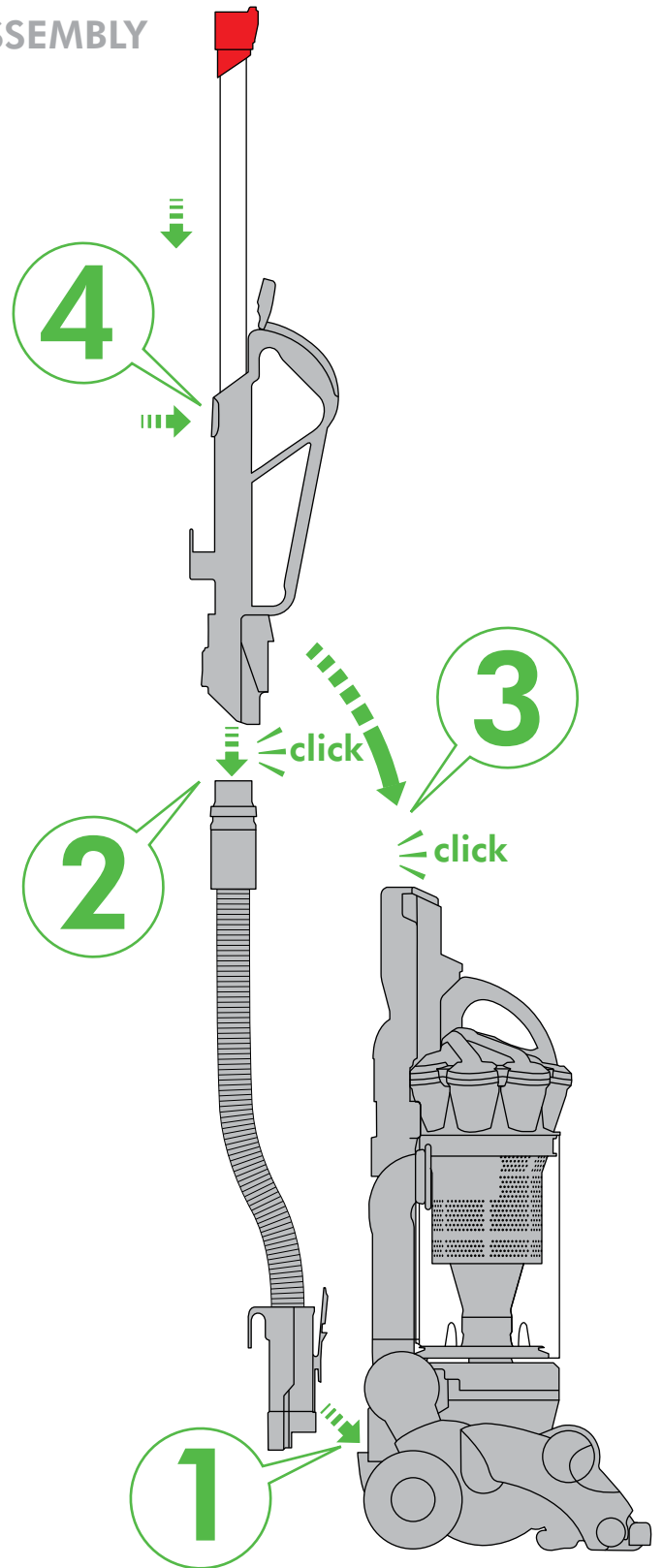

After registering for your 5 year guarantee, your Dyson vacuum cleaner will be covered for parts and labour for 5 years from the date of purchase, subject to the terms of the guarantee.

If you have a query about your Dyson vacuum cleaner, call the Dyson Customer Care Helpline with your serial number and details of where/when you bought the vacuum cleaner. Your serial number can be found on your rating plate which is behind the clear bin.

Most queries can be solved over the phone by one of our trained Dyson Customer Care Helpline staff.

Alternatively visit www.dyson.co.uk/support for online help, general tips and useful information about Dyson.

Note your serial number for future reference



This illustration is for example purposes only.

IMPORTANT SAFETY PRECAUTIONS

READ ALL INSTRUCTIONS BEFORE USING THIS APPLIANCE

When using an electrical appliance, basic precautions should always be followed, including the following:

WARNING

TO REDUCE THE RISK OF FIRE, ELECTRIC SHOCK, OR INJURY:

1. Do not leave the Dyson vacuum cleaner when plugged in. Unplug from socket when not in use and before servicing.
2. Do not use outdoors or on wet surfaces. Suitable for dry locations only. Do not use to pick up water.
3. Do not allow to be used as a toy. Close attention is necessary when used by or near children. Children should be supervised to ensure that they do not play with the Dyson vacuum cleaner.
4. This Dyson vacuum cleaner is not intended for use by young children or infirm persons with reduced physical, sensory or reasoning capabilities, or lack of experience and knowledge, unless they have been given supervision or instruction by a responsible person concerning use of the Dyson vacuum cleaner to ensure that they can use the Dyson vacuum cleaner safely.
5. Use only as described in this manual. Use only Dyson recommended accessories and replacement parts. Do not carry out any maintenance other than that shown in this manual, or advised by the Dyson Customer Care Helpline. Contact the Dyson Customer Care Helpline when service or repair is required. Do not disassemble the Dyson vacuum cleaner as incorrect reassembly may result in an electric shock or fire.
6. Do not use with a damaged cable or plug. If the Dyson vacuum cleaner is not working as it should, has been dropped, damaged, left outdoors, or dropped into water, do not use and contact the Dyson Customer Care Helpline. If the supply cable is damaged it must be replaced by Dyson, its service agent or similarly qualified person in order to avoid a hazard.
7. Do not pull or carry by cable, use cable as a handle, close a door on cable, or pull cable around sharp edges or corners. Do not run the Dyson vacuum cleaner over cable. Keep cable away from heated surfaces. To avoid a tripping hazard wind the cable when not in use.
8. Do not unplug by pulling on the cable. To unplug, grasp the plug, not the cable.
9. Do not handle the plug or Dyson vacuum cleaner with wet hands.
10. Do not put any object into openings. Do not use with any opening blocked; keep free of dust, lint, hair, and anything that may reduce airflow.
11. Keep hair, loose clothing, fingers, and all parts of body away from openings and moving parts, such as the brush bar. Do not point the hose, wand or tools at your eyes or ears or put them in your mouth.
12. Turn off all controls before unplugging.
13. Use extra care when cleaning on stairs. Do not work with the Dyson vacuum cleaner above you on the stairs.
14. Do not use to pick up flammable or combustible liquids, such as petrol, or use in areas where they or their vapours may be present.
15. Do not pick up anything that is burning or smoking, such as cigarettes, matches, or hot ashes.
16. Do not use without the clear bin and filters in place.
17. The use of an extension cable is not recommended.

READ AND SAVE THESE INSTRUCTIONS

THIS DYSON VACUUM CLEANER IS INTENDED FOR HOUSEHOLD USE ONLY

3 EASY WAYS TO REGISTER FOR YOUR FREE 5 YEAR GUARANTEE

REGISTER ONLINE
Visit our website to register your full parts and labour guarantee online.
www.dyson.com/register

REGISTER BY PHONE
Call our dedicated Helpline. Open 7am–10pm. 7 days a week.
UK 0800 298 0298
ROI 01 475 7109

REGISTER BY MAIL
Complete and return the form to Dyson in the envelope supplied.

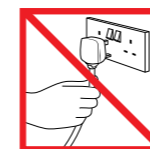

Do not pull on the cable.

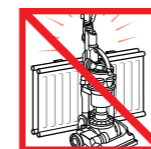

Do not store near heat sources.



Do not use near naked flame.

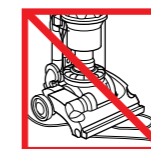

Do not run over the cable.



Do not pick up water or liquids.



Do not pick up burning objects.



Do not use above you on the stairs.

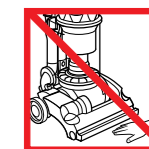

Do not put hands near the brush bar when the vacuum cleaner is in use.

Using your Dyson vacuum cleaner

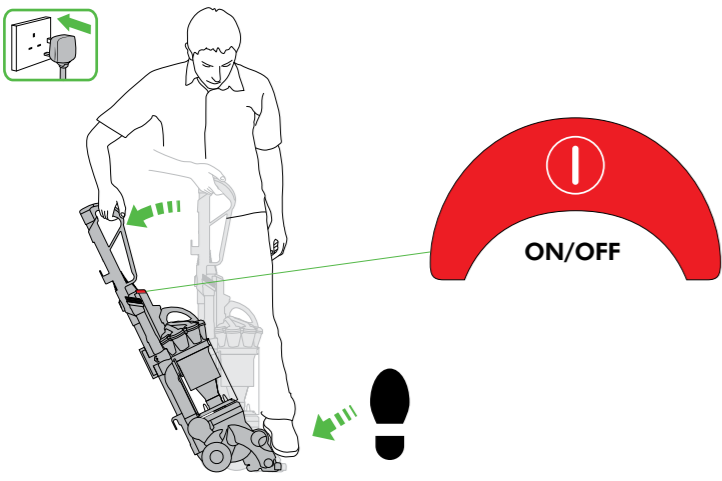

Carrying your Dyson vacuum cleaner

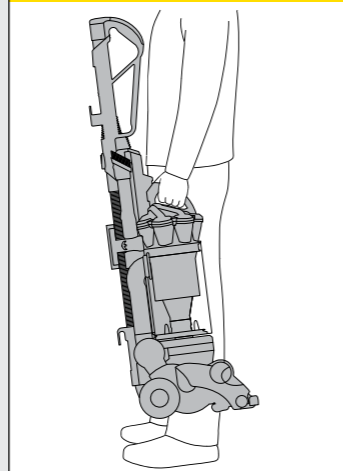

Looking for blockages

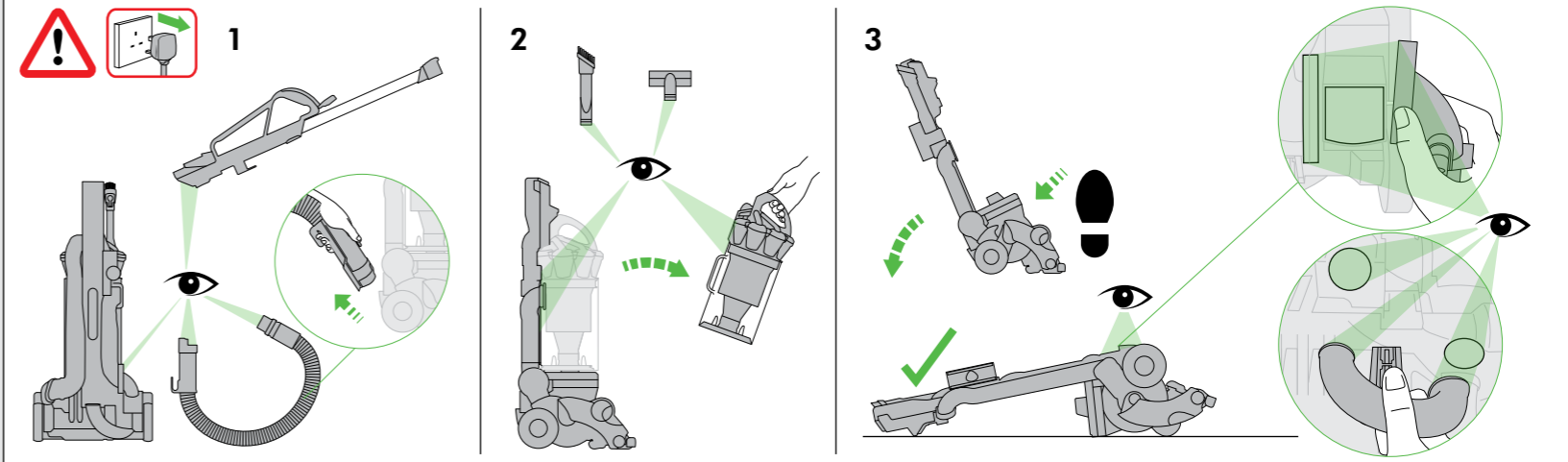

Emptying the clear bin

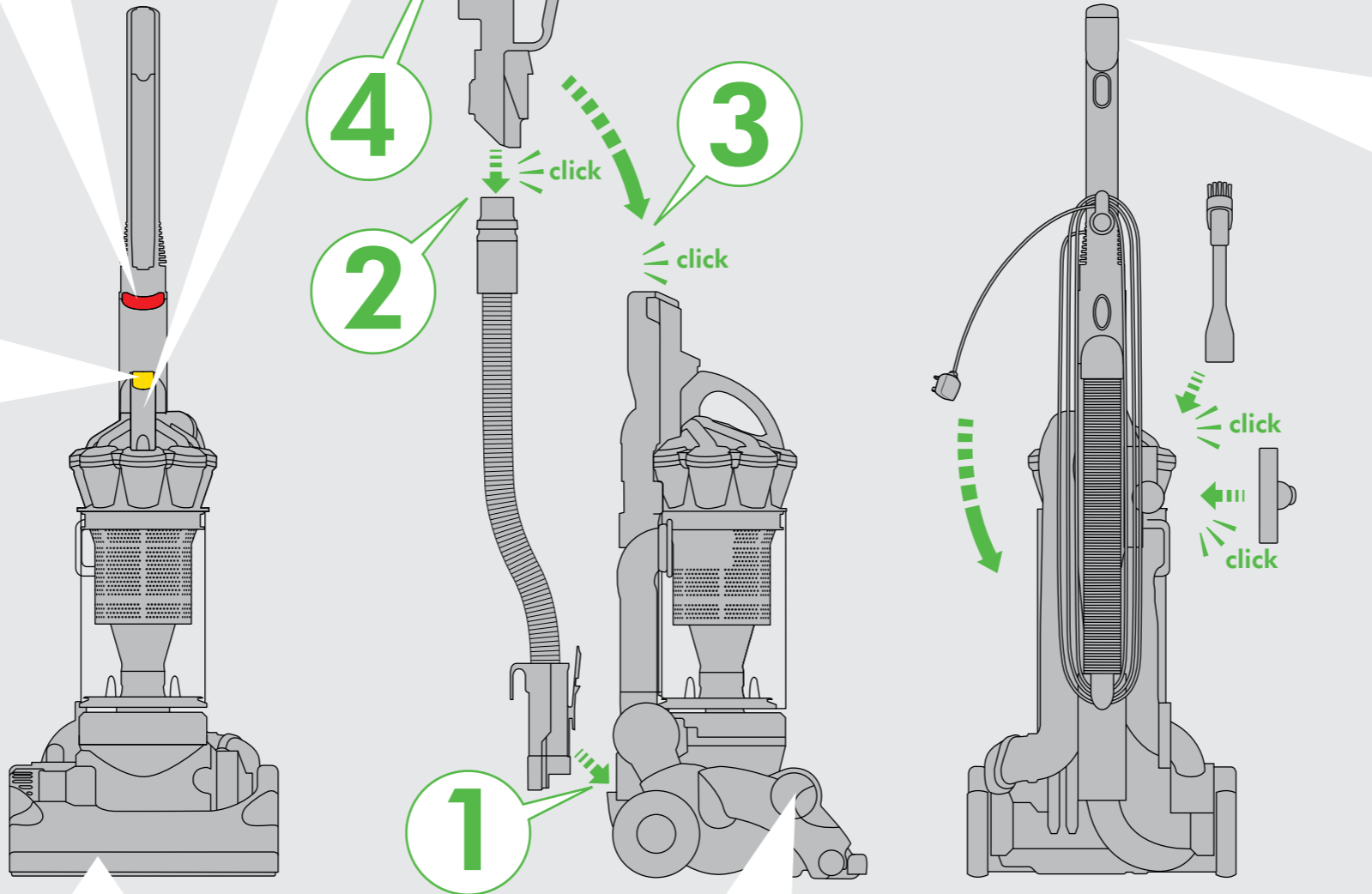
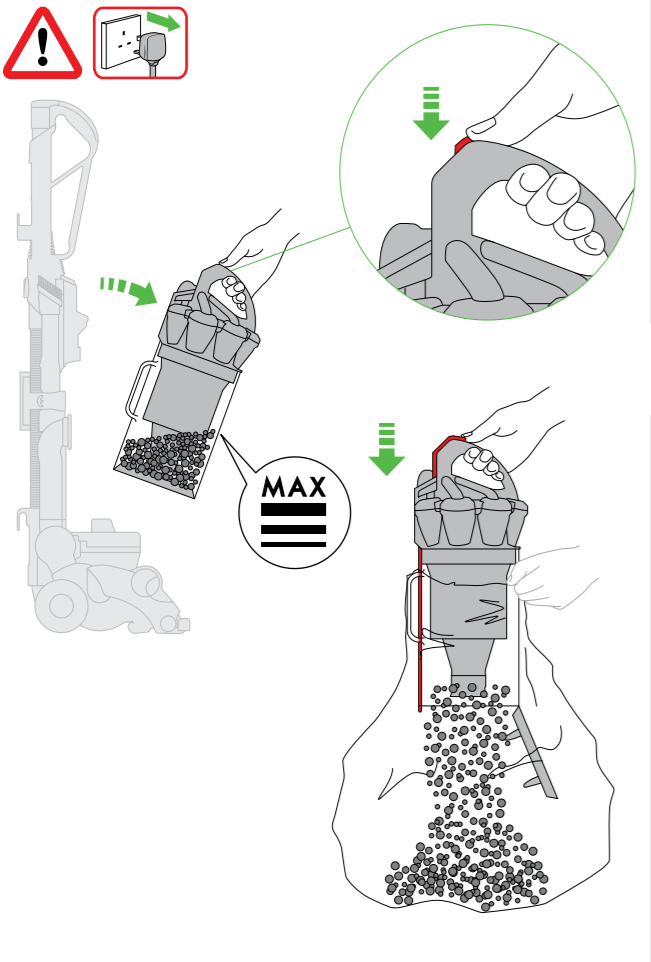

High-reach cleaning

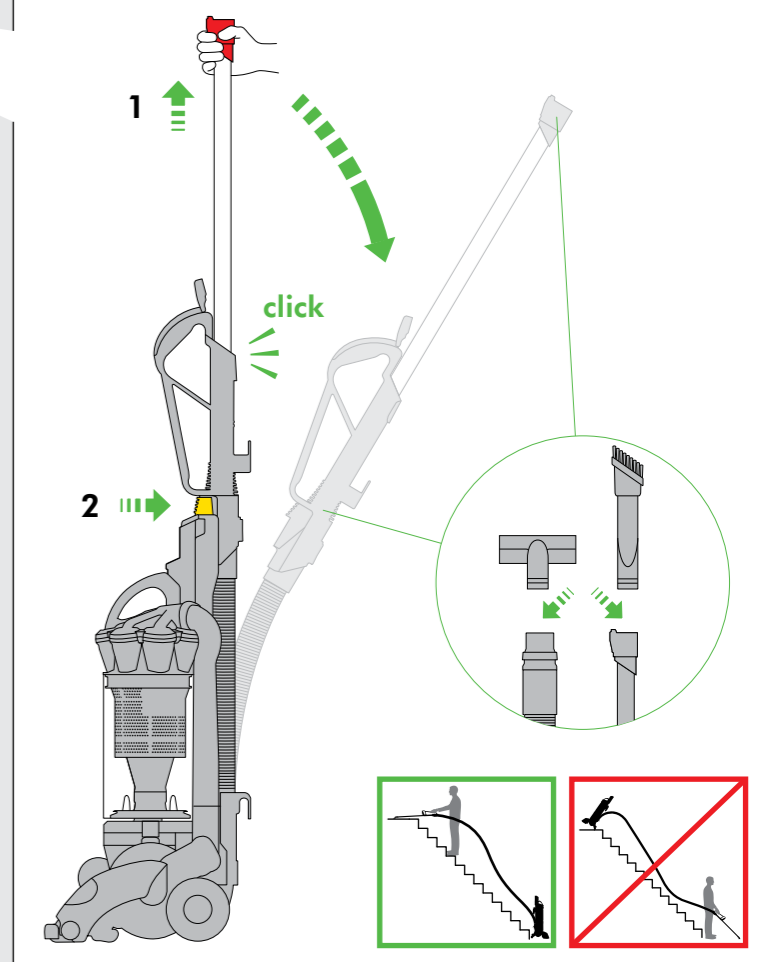

Clearing brush bar obstructions

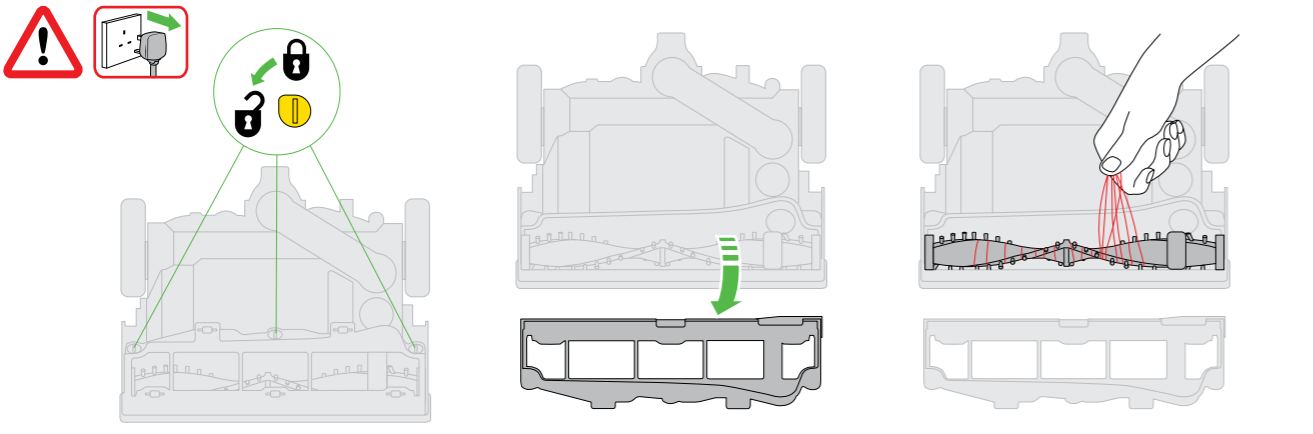

Hard floors/carpets

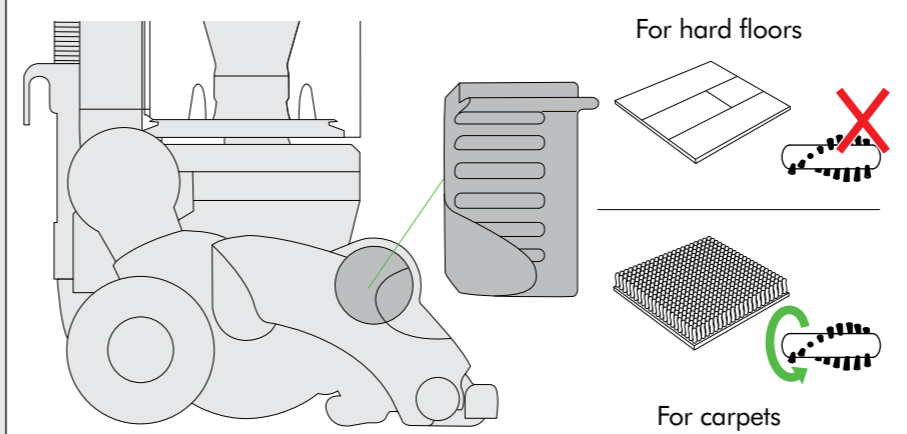

Turbine maintenance*

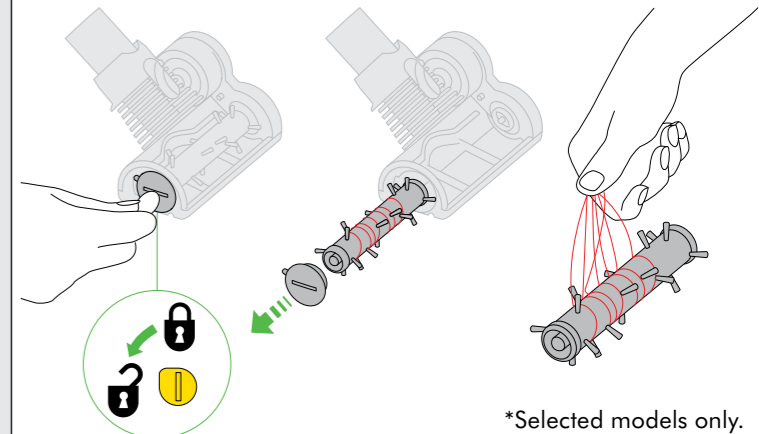

*Selected models only.

IMPORTANT!

WASH FILTERS



Wash filters with cold water at least every 3 months.

  **Filter A**

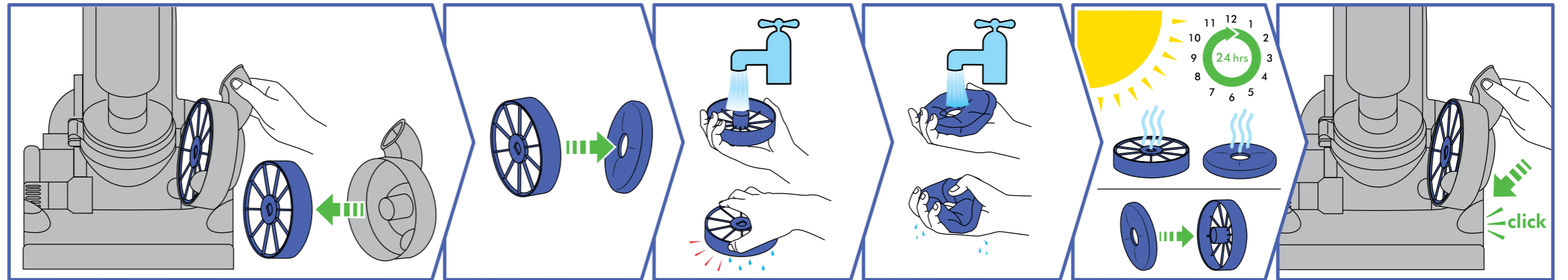

  **Filter B**

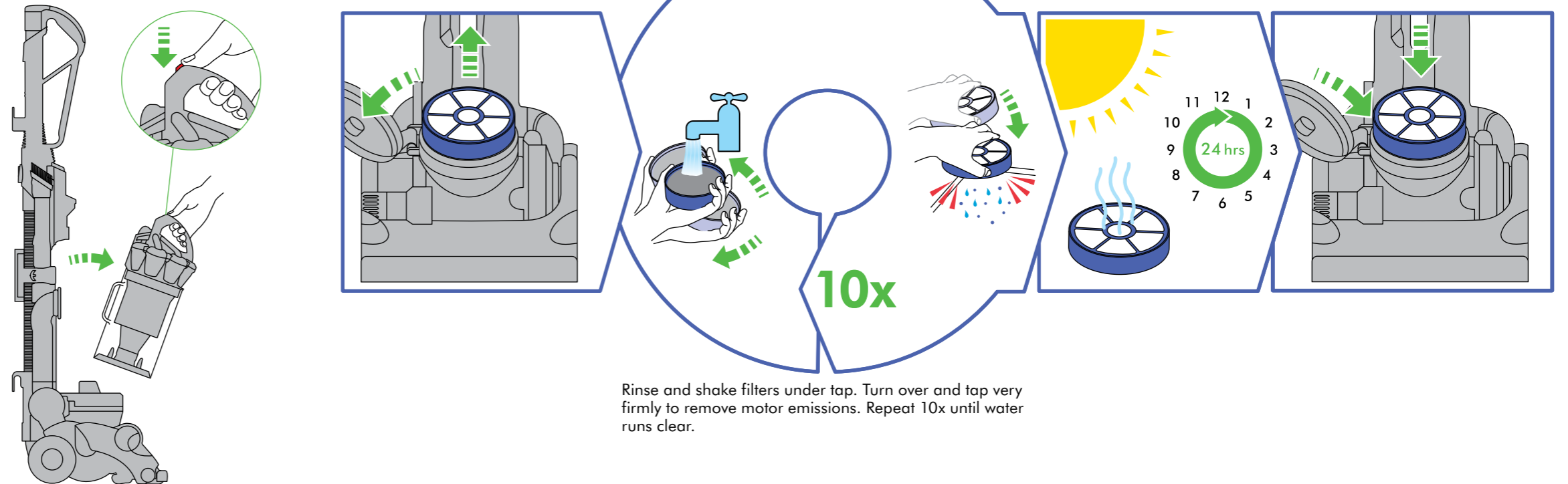

Rinse and shake filters under tap. Turn over and tap very firmly to remove motor emissions. Repeat 10x until water runs clear.

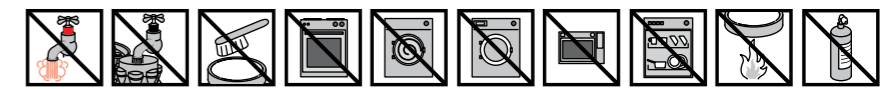
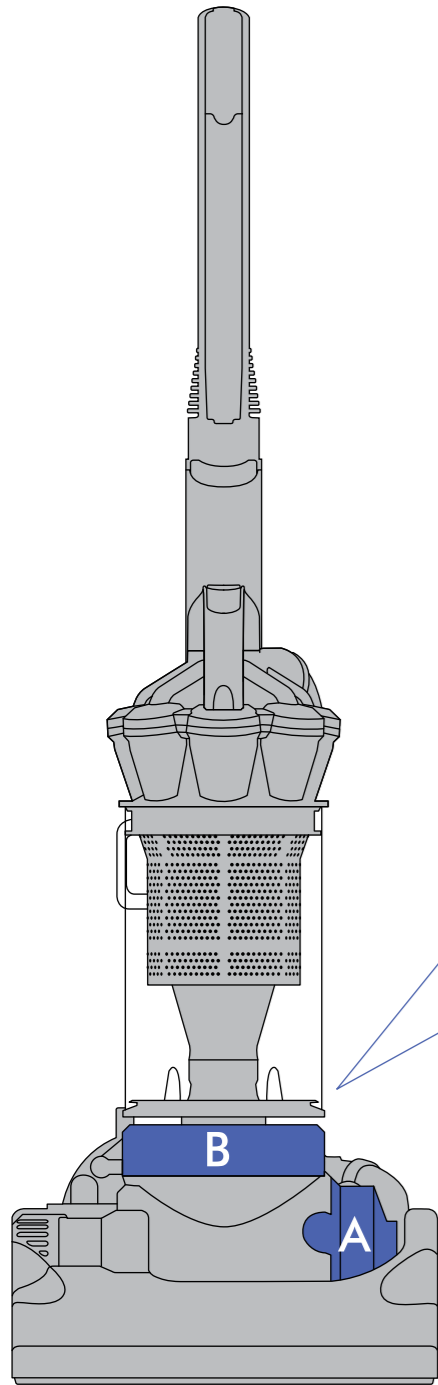

ASSEMBLY

- Stand the vacuum cleaner up straight and slide the hose into guides at the back of the vacuum cleaner and click into place.
- Ensure the hose is straight and slide the wand straight down into the hose until it clicks into place.
- Click the wand handle into the top of the vacuum cleaner. Press the red button on the rear of the wand handle and slide the tube down. Close the wand cap.
- Attach the tools to the vacuum cleaner and wind the cable anti-clockwise around cable hooks and secure with clip.

USING YOUR DYSON VACUUM CLEANER

Unwind the cable and insert the plug into a suitable socket. Hold the cleaner head down with your foot and pull the handle downwards. To switch ‘ON’ or ‘OFF’ press the power button in front of the handle.



CAUTION:

- Do not allow the vacuum cleaner to be used by anyone who may not be able to operate it safely.
- The use of an extension cable is not recommended.
- Always switch ‘OFF’ and unplug before performing maintenance on your vacuum cleaner.
- When returning to the upright position, ensure that the wand and clear bin assembly are fully upright before releasing the vacuum cleaner.
- Ensure the cyclone is secured to the vacuum cleaner. Do not press the cyclone release button or shake the vacuum cleaner while carrying or it could fall and cause injury.
- Store the vacuum cleaner indoors. Put the vacuum cleaner away after use with the cable coiled safely, to prevent tripping hazards.
- Do not use outdoors or on wet surfaces or to vacuum water or other liquids – electric shock could occur.
- Do not lubricate any parts, or carry out any maintenance or repair work other than that shown in this manual, or advised by the Dyson Custome Care Helpline.

PLEASE NOTE:

- This vacuum cleaner is intended for domestic use only. Fine dust such as plaster dust or flour should only be vacuumed in very small amounts.
- Do not use the vacuum cleaner to pick up sharp hard objects, small toys, pins, paper clips, etc. They may damage the vacuum cleaner.
- If used in a garage, care should be taken to wipe the soleplate and wheels with a dry cloth after vacuuming to clean off any sand, dirt, or pebbles that could damage delicate floors.
- Consult your flooring manufacturer’s recommended instructions before vacuuming and caring for your flooring, rugs, and carpet. Some carpets will fuzz if a rotating brush bar is used when vacuuming. If this happens, we recommend vacuuming in hard floors mode and consulting with your flooring manufacturer.
- When vacuuming, certain carpets may generate small static charges in the clear bin. These are entirely harmless and are not associated with the mains supply. To minimise any effect from this, do not put your hand or insert any object into the clear bin unless you have first emptied it and rinsed it out with cold water. (See ‘Cleaning the clear bin’ section.)
- Do not use or store this vacuum cleaner below 0°C (32°F). Ensure that the vacuum cleaner is at room temperature before operating.

HARD FLOORS/CARPETS

Ensure the machine is in an upright position before adjusting the setting. The brush bar will automatically stop if it becomes obstructed. If the brush bar stops during use, please refer to the ‘Clearing brush bar obstructions’ section.

HIGH-REACH CLEANING



CAUTION:

- Switch ‘OFF’ the vacuum cleaner before changing tools.
- Powerful suction can cause the hose to ‘pull back’ - please take care.
- Take extra care when vacuuming on stairs; do not work with the vacuum cleaner above you on the stairs. Do not put the vacuum cleaner on chairs, tables etc.
- Ensure vacuum cleaner is in upright position before using tools.

PLEASE NOTE:

- To release the wand, open the wand cap and pull the red tube from inside the handle until it clicks. Press button to release the wand and hose from the machine. Tools can be attached to either the hose or wand.
- The brush bar will not rotate when the vacuum cleaner is in an upright position.
- Ensure wand cap is closed when not in use.

EMPTYING THE CLEAR BIN



CAUTION:

- Switch ‘OFF’ the vacuum cleaner and unplug before emptying the clear bin.
- Empty as soon as the dirt reaches the level of the MAX mark – do not overfill.
- To remove the clear bin from the vacuum cleaner, press the button at the rear of cyclone carrying handle. To release the dirt, press the red bin release button. Emptying into a bag is recommended for allergy sufferers.
- Do not use the vacuum cleaner without the clear bin in place.
- To minimise dust/allergen contact when emptying, encase the clear bin tightly in a plastic bag and empty. Remove the clear bin carefully and seal bag tightly, dispose as normal. For a free fact sheet visit www.dyson.co.uk/technology/allergy

CLEANING THE CLEAR BIN



CAUTION:

To remove the cyclone unit from the clear bin press the red bin release button. This exposes a small silver button behind the red opening mechanism. Press the silver button and separate the cyclone unit from the clear bin.

- Clean the clear bin with cold water only.
- Ensure the clear bin is completely dry before replacing.

PLEASE NOTE:

- Do not use detergents, polishes or air fresheners to clean the clear bin.
- Do not put clear bin in a dishwasher.
- Clean the shroud with a cloth or dry brush to remove lint and dust.

WASHING YOUR FILTERS

DO THIS EVERY 3 MONTHS



CAUTION:

- Switch ‘OFF’ and unplug the vacuum cleaner before removing the filters.
- Ensure filters are completely dry before refitting to the vacuum cleaner.

PLEASE NOTE:

This machine has two filters, located as shown. It is important to check your filters regularly and wash at least every 3 months according to instructions, to maintain performance. Filter B should be rinsed and tapped out until the water runs clean, then tapped out again to ensure all excess water is removed. This will normally require up to 10 rinse cycles.

- After washing please leave for 24 hours to dry completely.
- The filters may require more frequent washing if vacuuming fine dust.
- Do not use detergents to clean the filters.
- Do not put the filters in a dishwasher, washing machine, tumble dryer, oven, microwave or near a naked flame.

LOOKING FOR BLOCKAGES



CAUTION:

- Switch ‘OFF’ and unplug the vacuum cleaner before checking for blockages. Failure to do so could result in personal injury.
- Please ensure the vacuum cleaner is upright and switched off before removing hose or airway inspection parts.
- Beware of sharp objects when clearing blockages.
- Refit all parts of the vacuum cleaner securely before using.

PLEASE NOTE:

- Clearing blockages is not covered by your vacuum cleaner’s limited guarantee.
- This vacuum cleaner is fitted with an automatically resetting thermal cut-out. If any part of the vacuum cleaner becomes blocked, it may overheat and automatically cut-out. Switch ‘OFF’ and unplug the vacuum cleaner and leave to cool down for 1-2 hours before checking filters or for blockages.

CLEARING BRUSH BAR OBSTRUCTIONS



CAUTION:

- Switch ‘OFF’ and unplug the vacuum cleaner before clearing brush bar obstructions. Failure to do so could result in personal injury.
- Beware of sharp objects when clearing obstructions.
- Refit all parts of the vacuum cleaner securely before using.

PLEASE NOTE:

- Clearing brush bar obstructions is not covered by your vacuum cleaner’s limited guarantee.

BRUSH BAR TROUBLESHOOTING

If the brush bar has stopped spinning, follow the steps below. Alternatively contact a Dyson expert on UK 0800 298 0298 or ROI 01 475 7109 or visit www.dyson.co.uk/support



CAUTION:

- Ensure machine is in reclined position.
- Ensure clutch is turned on (See page 3).
- Check the cleaner head for blockages (i.e. tangled hair, large debris).
- If the brush bar still isn’t spinning, contact a Dyson expert on UK 0800 298 0298 or ROI 01 475 7109.

DISPOSAL INFORMATION

Dyson products are made from high grade recyclable materials. Please dispose of this product responsibly and recycle where possible.

DYSON CUSTOMER CARE

THANK YOU FOR CHOOSING TO BUY A DYSON VACUUM CLEANER

If you have a query about your Dyson vacuum cleaner, most times these can be solved over the phone by one of our Dyson Customer Care Helpline staff, or by visiting www.dyson.co.uk/support.

Have your serial number and details of where and when you bought the vacuum cleaner to hand. The serial number can be found on the main body of the vacuum cleaner behind the clear bin.

If your vacuum cleaner needs a service, call the Dyson Customer Care Helpline so we can discuss the available options. If your vacuum cleaner is under guarantee, and the repair is covered, it will be repaired at no cost.

PLEASE REGISTER AS A DYSON VACUUM OWNER

To help us ensure you receive prompt and efficient service, please register as a Dyson vacuum cleaner owner. There are three ways to do this:

- Online at www.dyson.com/register
- By calling the Dyson Customer Care Helpline on UK 0800 298 0298 or ROI 01 475 7109.
- By completing and returning the enclosed form to us by mail. This will confirm ownership of your Dyson vacuum cleaner in the event of an insurance loss, and enable us to contact you if necessary.

LIMITED 5 YEAR GUARANTEE

TERMS AND CONDITIONS OF THE DYSON 5 YEAR LIMITED GUARANTEE.

WHAT IS COVERED

- The repair or replacement of your vacuum cleaner (at Dyson’s discretion) if your vacuum cleaner is found to be defective due to faulty materials, workmanship or function within 5 years of purchase or delivery (if any part is no longer available or out of manufacture Dyson will replace it with a functional replacement part).
- Use of the vacuum cleaner in the UK and Republic of Ireland.

WHAT IS NOT COVERED

Dyson does not guarantee the repair or replacement of a product as a result of:

- Normal wear and tear (e.g. fuse, belt, brush bar, batteries etc).
- Accidental damage, faults caused by negligent use or care, misuse, neglect, careless operation or handling of the vacuum cleaner which is not in accordance with the Dyson Operating Manual.
- Blockages – please refer to the Dyson Operating Manual for details of how to unblock your vacuum cleaner.
- Use of the vacuum cleaner for anything other than normal domestic household purposes.
- Use of parts not assembled or installed in accordance with the instructions of Dyson.
- Use of parts and accessories which are not Dyson Genuine Components.
- Faulty installation (except where installed by Dyson).
- Repairs or alterations carried out by parties other than Dyson or its authorised agents.

If you are in any doubt as to what is covered by your guarantee, please call the Dyson Customer Care Helpline on UK 0800 298 0298 or ROI 01 475 7109 or visit www.dyson.co.uk/support

SUMMARY OF COVER

- The guarantee becomes effective at the date of purchase (or the date of delivery if this is later).
- You must provide proof of delivery/purchase before any work can be carried out on your vacuum cleaner. Without this proof, any work carried out will be chargeable. Please keep your receipt or delivery note.
- All work will be carried out by Dyson or its authorised agents.
- Any parts which are replaced will become the property of Dyson.
- The repair or replacement of your vacuum cleaner under guarantee will not extend the period of guarantee.
- The guarantee provides benefits which are additional to and do not affect your statutory rights as a consumer.

ABOUT YOUR PRIVACY

If your personal details change, if you change your mind about any of your marketing preferences or if you have any queries about how we use your information, please let us know by contacting Dyson Limited, Tetbury Hill, Malmesbury, Wiltshire, SN16 0RP England, or by calling the Dyson Customer Care Helpline on UK 0800 298 0298 or ROI 01 475 7109. Or you can email us at askdyson@dyson.co.uk

For more information on how we protect your privacy, please see our privacy policy on www.dyson.co.uk

PRODUCT INFORMATION

Net weight: 7.80kg.

Please note: Small details may vary from those shown.

IMPORTANT!

WASH FILTERS



Wash filters with cold water at least every 3 months.



Dyson Customer Care

If you have a query about your Dyson vacuum cleaner, call the Dyson Customer Care Helpline with your serial number and details of where and when you bought the vacuum cleaner, or visit www.dyson.co.uk/support. The serial number can be found on the main body of the vacuum cleaner behind the clear bin.

UK Dyson Customer Care

askdyson@dyson.co.uk
0800 298 0298

Dyson Ltd, Tetbury Hill, Malmesbury, Wiltshire SN16 0RP.

ROI Dyson Customer Care

irelandservice@dyson.com
01 475 7109

Dyson Ireland Limited, Unit G10, Grants Lane,
Greenogue Business Park, Rathcoole, Dublin 24.

Serial number

Date of purchase / / Country of purchase UK ROI

Title Surname

First name

Address

Postcode

email

Telephone Mobile

As a Dyson vacuum cleaner owner, you can hear about Dyson inventions, services and products before anyone else. If it's okay to contact you, please let us know how we may do this.

We sometimes ask other companies (such as market researchers) to contact owners on our behalf. We do this to get feedback on ideas or ask you to try new products and services. Would this be okay?

By mail Yes No Yes No

By phone Yes No

By email Yes No

By text message Yes No

3 EASY WAYS TO REGISTER FOR YOUR FREE 5 YEAR GUARANTEE



REGISTER ONLINE

Visit our website to register your full parts and labour guarantee online.

www.dyson.com/register



REGISTER BY PHONE

Call our dedicated Helpline. Open 7am–10pm. 7 days a week.

UK 0800 298 0298
ROI 01 475 7109



REGISTER BY MAIL

Complete and return the form to Dyson in the envelope supplied.

