



# Searwood 600 / XL 600

MONTAGEHANDLEIDING

INSTRUCTIONS DE MONTAGE

MONTAGEANLEITUNG

GUIDA DI ASSEMBLAGGIO



**BILT**

Download on the  
App Store

GET IT ON  
Google Play

9501065





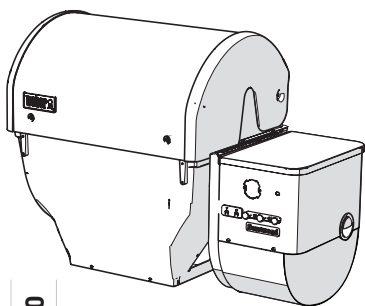

07/31/24



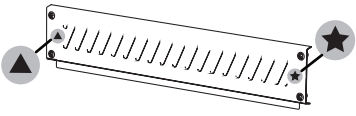
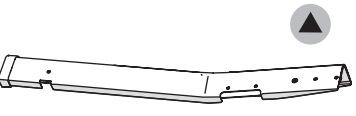
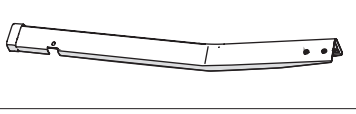
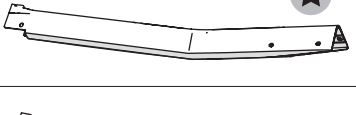

NL/DE/FR/IT

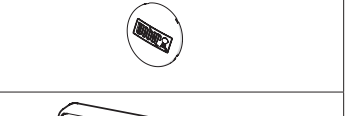

600	XL 600	
1	1	
1	1	
0	1	
1	1	
1	1	
1	1	

600	XL 600	
1	1	
1	1	
2	2	
2	2	
1	1	
1	1	
1	1	
1	1	
2	2	

600	XL 600	
1	1	
1	1	
1	1	
1	1	
1	1	
1	1	
1	1	
1	1	
2	2	

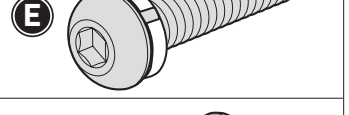
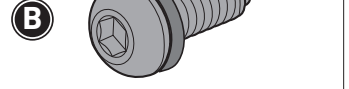
600	XL 600	
2	2	
1	1	
1	1	
2	2	
4	4	
2	2	
20	20	

## INBEGREPEN GEREEDSCHAPPEN:

### ENTHALTENE WERKZEUGE:



### OUTILS INCLUS :

### ATTREZZI INCLUSI:

- NL** ⚠ Er zijn twee personen nodig voor de montage.  
⚠ Monteer de barbecue op een vlakke, horizontale en zachte ondergrond.  
⚠ Gebruik geen elektrisch gereedschap voor de montage.  
⚠ Houd het deksel altijd gesloten tijdens het monteren of verplaatsen van de barbecue, tenzij anders aangegeven.  
⚠ Zorg ervoor dat alle onderdelen zijn gemonteerd en de schroeven volledig zijn aangedraaid voordat je de barbecue in gebruik neemt.  
⚠ Verwijder alle verpakingsmaterialen en beschermfolie voordat je de barbecue in gebruik neemt.  
⚠ Bewaar de volledige verpakking om schade aan de barbecue tijdens de montage te voorkomen.
- DE** ⚠ Die Montage muss von zwei Personen durchgeführt werden.  
⚠ Den Grill auf einer flachen, ebenen und weichen Unterlage montieren.  
⚠ Für die Montage keine Elektrowerkzeuge verwenden.  
⚠ Halte den Deckel immer geschlossen, wenn du den Grill zusammenbaust oder bewegst, sofern nicht anders angegeben.  
⚠ Stelle sicher, dass alle Teile ordnungsgemäß zusammengebaut und sicher befestigt sind, bevor du den Grill in Betrieb nimmst.  
⚠ Entferne vor der Inbetriebnahme des Grills sämtliches Verpackungsmaterial und alle Schutzfolien.  
⚠ Bewahre alle Verpackungen auf, um Beschädigungen des Grills während der Montage zu vermeiden.
- FR** ⚠ Le montage requiert deux personnes.  
⚠ Procédez au montage du barbecue sur une surface horizontale, plane et non rugueuse.  
⚠ N'utilisez pas d'outils électriques pour le montage.  
⚠ Gardez toujours le couvercle fermé lorsque vous montez ou déplacez le barbecue, sauf indication contraire.  
⚠ Assurez-vous que toutes les pièces sont assemblées et que toutes les vis sont serrées avant de faire fonctionner votre barbecue.  
⚠ Retirez tous les éléments d'emballage et les films protecteurs avant d'allumer votre barbecue.  
⚠ Conservez tous les emballages pour éviter d'endommager le barbecue pendant le montage.
- IT** ⚠ Per l'assemblaggio sono necessarie due persone.  
⚠ Assemblare il barbecue su una superficie piana, orizzontale e morbida.  
⚠ Non utilizzare attrezzi elettrici per l'assemblaggio.  
⚠ Tenere sempre chiuso il coperchio durante l'assemblaggio o la movimentazione del barbecue, salvo diversa indicazione.  
⚠ Prima di utilizzare il barbecue, assicurarsi che tutte le parti siano assemblate e che la minuteria sia serrata.  
⚠ Rimuovere tutti gli imballaggi e la pellicola protettiva prima di accendere il barbecue.  
⚠ Conservare tutti gli imballaggi per evitare di danneggiare il barbecue durante l'assemblaggio.



**1**

**Let op:** Voor deze montageslap zijn twee mensen nodig.

**Hinweis:** Für diesen Montageschritt werden zwei Personen benötigt.

**N. B. :** cette étape du montage requiert deux personnes.

**Nota:** per questa fase di assemblaggio sono necessarie due persone.

△ Verwijder voldoende pakketten uit de ketel om het deksel te verwijderen en verwijder vervolgens alle resterende pakketten uit de ketel.

△ Entferne genügend Pakete aus der Grillkammer, um den Deckel zu entfernen, und entferne dann alle übrigen Pakete aus der Grillkammer.

△ Retirez suffisamment d'emballages de la cuve de cuisson pour retirer le couvercle, puis retirez tous les emballages restants de la cuve de cuisson.

△ Rimuovere dal braciere un numero sufficiente di confezioni per rimuovere il coperchio, quindi rimuovere tutte le confezioni rimanenti dal braciere.

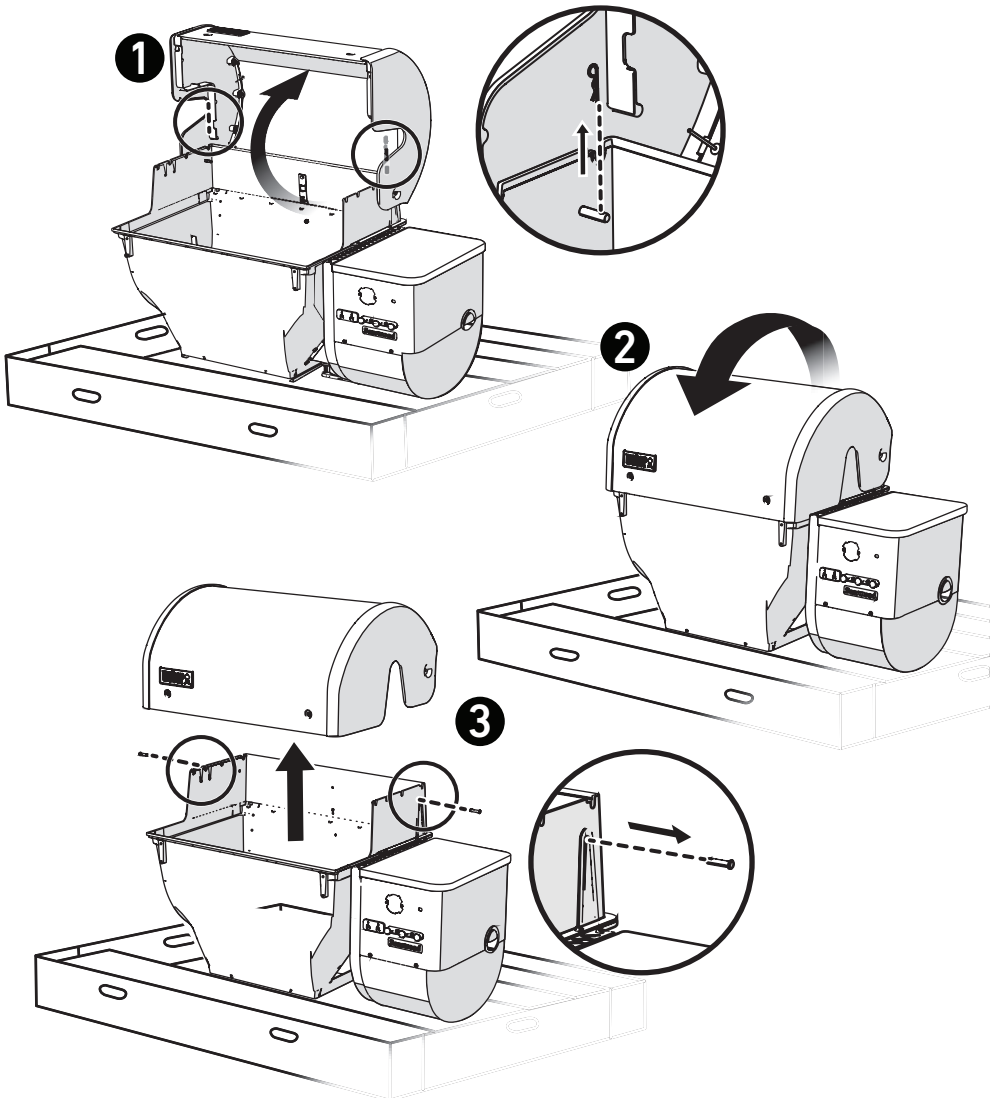

2

B

4-

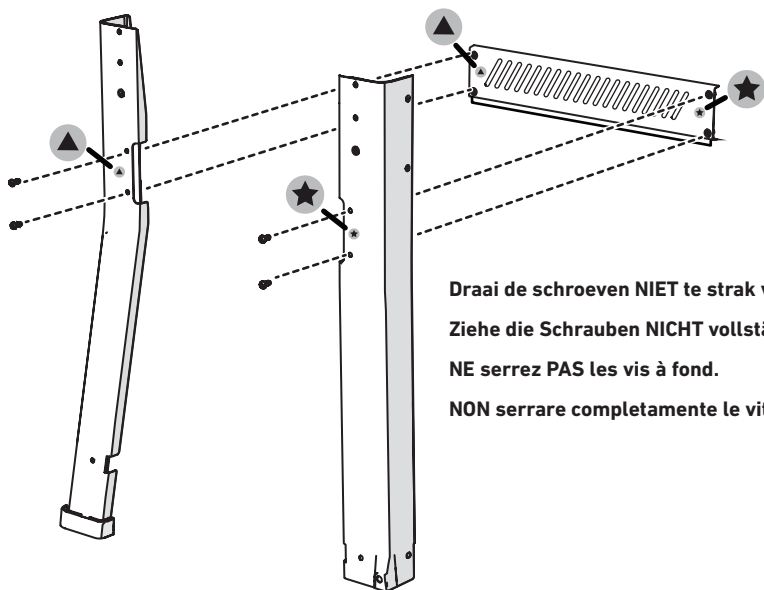
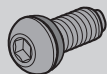

Draai de schroeven NIET te strak vast.

Ziehe die Schrauben NICHT volledig an.

NE serrez PAS les vis à fond.

NON serrare completamente le viti.

3



**Let op:** Voor deze montagesap zijn twee mensen nodig.

**Hinweis:** Für diesen Montageschritt werden zwei Personen benötigt.

**N. B. :** cette étape du montage requiert deux personnes.

**Nota:** per questa fase di assemblaggio sono necessarie due persone.

- △ Gebruik de verpakking om de barbecue te beschermen tegen schade tijdens de montage.
- △ Verwende die Verpakking, um den Grill während der Montage vor Beschädigungen zu schützen.
- △ Utilisez l'emballage pour protéger le barbecue de tout dommage pendant le montage.
- △ Utilizzare l'imballaggio per evitare di danneggiare il barbecue durante l'assemblaggio.

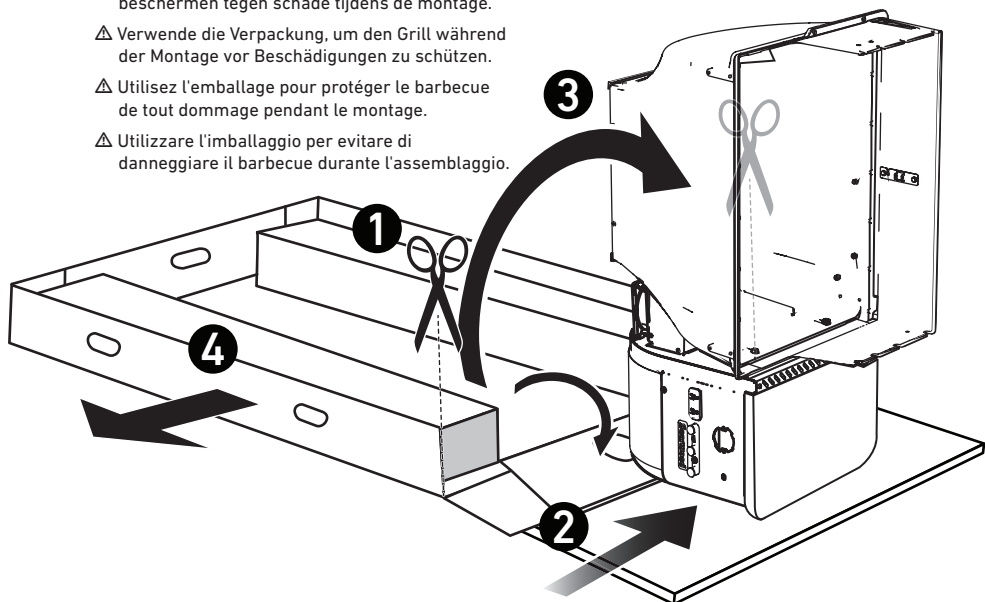

4



**Let op:** Voor deze montagesap zijn twee mensen nodig.

**Hinweis:** Für diesen Montageschritt werden zwei Personen benötigt.

**N. B. :** cette étape du montage requiert deux personnes.

**Nota:** per questa fase di assemblaggio sono necessarie due persone.

B

4-

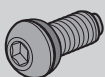

Draai de schroeven NIET te strak vast.

Ziehe die Schrauben NICHT vollständig an.

NE serrez PAS les vis à fond.

NON serrare completamente le viti.

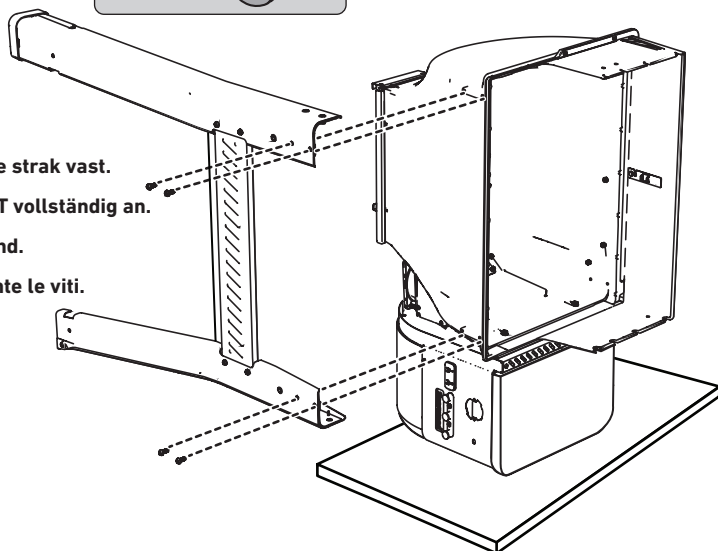

5

B

2-

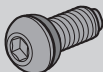

Draai de schroeven NIET te strak vast.

Ziehe die Schrauben NICHT vollständig an.

NE serrez PAS les vis à fond.

NON serrare completamente le viti.

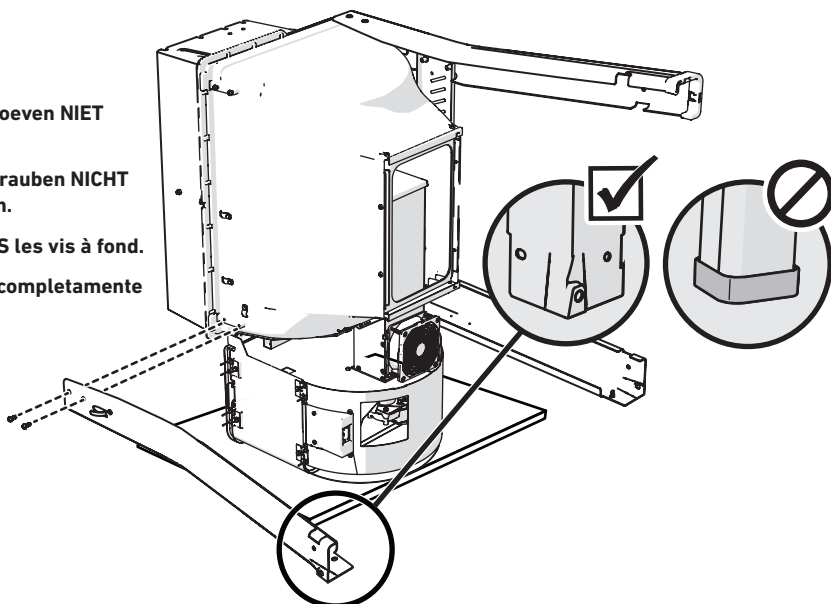

6

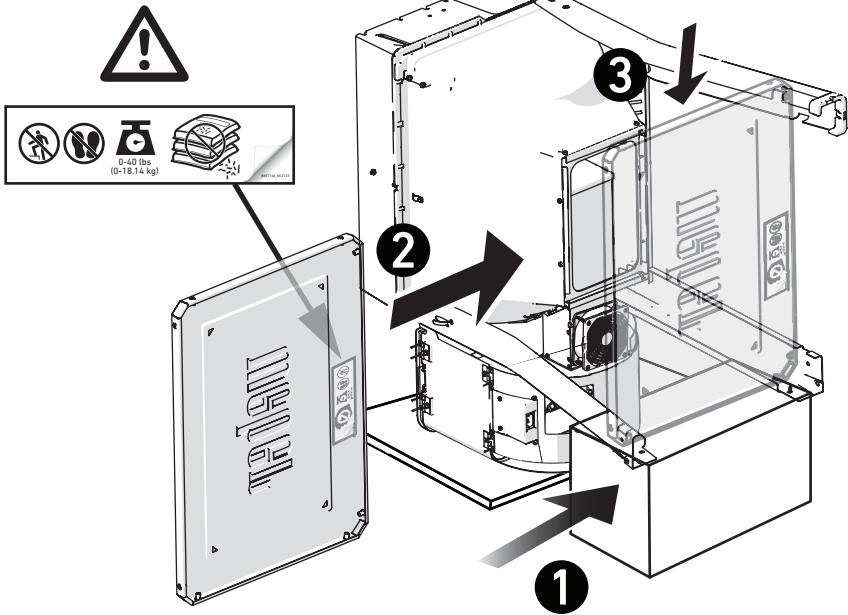

⚠ Gebruik de verpakking om de barbecue te beschermen tegen schade tijdens de montage.

⚠ Verwende die Verpakking, um den Grill während der Montage vor Beschädigungen zu schützen.

⚠ Utilisez l'emballage pour protéger le barbecue de tout dommage pendant le montage.

⚠ Utilizzare l'imballaggio per evitare di danneggiare il barbecue durante l'assemblaggio.



**B 4-**  
Draai de schroeven NIET te strak vast.

Ziehe die Schrauben NICHT vollständig an.

NE serrez PAS les vis à fond.

NON serrare completamente le viti.

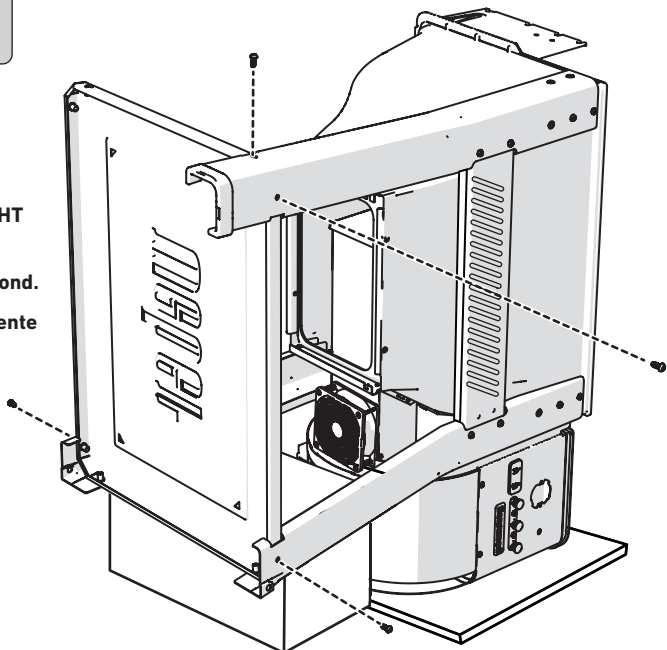

7

B

6-

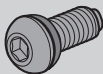

- Draai ALLE schroeven volledig vast voordat je de barbecue rechtop zet.
- Ziehe ALLE Schrauben fest an, bevor du den Grill aufrecht hinstellst.
- Serrez à fond TOUTES les vis avant de lever le barbecue à la verticale.
- Serrare completamente TUTTE le viti prima di sollevare il barbecue in posizione verticale.

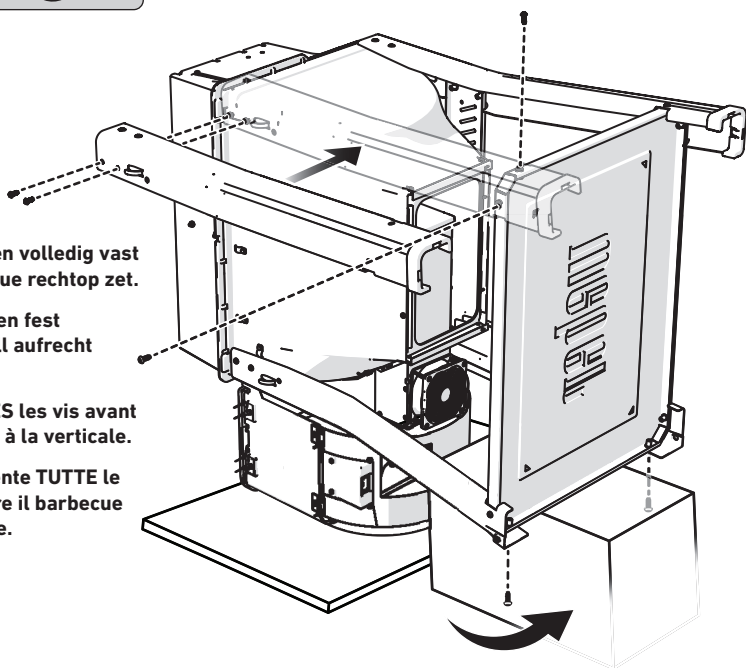

8

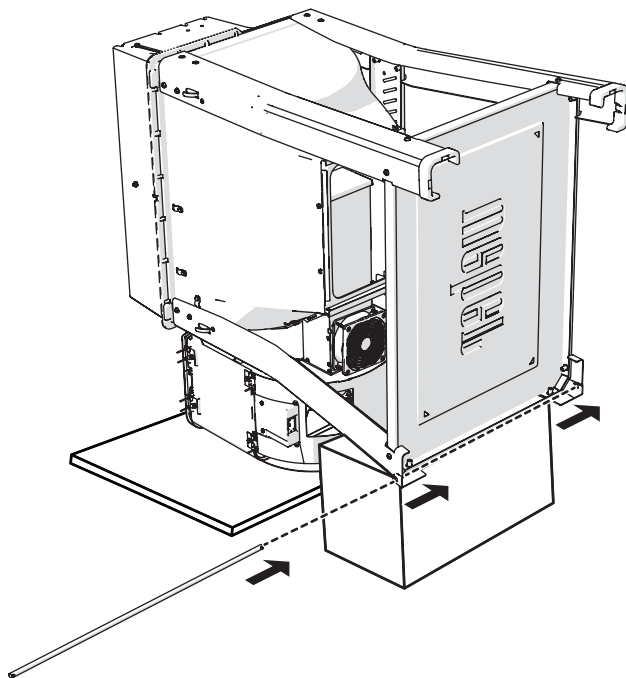

9

C 2- 

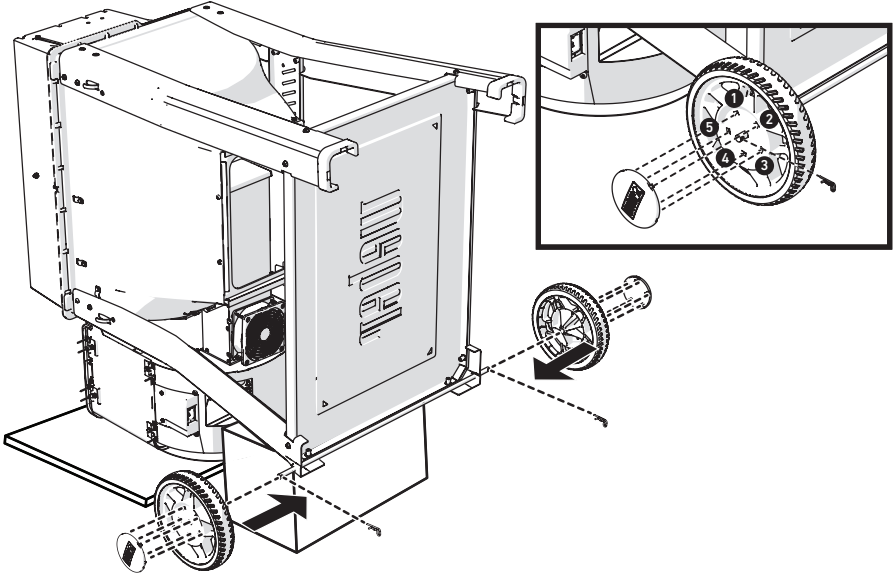

10

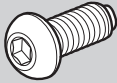
D 4- 

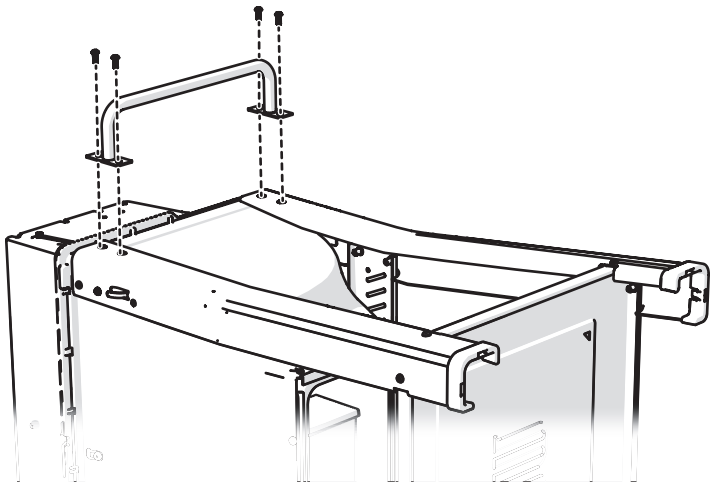

**11**

**Let op:** Voor deze montagesap zijn twee mensen nodig.

**Hinweis:** Für diesen Montageschritt werden zwei Personen benötigt.

**N. B. :** cette étape du montage requiert deux personnes.

**Nota:** per questa fase di assemblaggio sono necessarie due persone.

• Draai **ALLE** schroeven volledig vast voordat je de barbecue rechtop zet.

• Ziehe **ALLE** Schrauben fest an, bevor du den Grill aufrecht hinstellst.

• Serrez à fond **TOUTES** les vis avant de lever le barbecue à la verticale.

• Serrare completamente **TUTTE** le viti prima di sollevare il barbecue in posizione verticale.

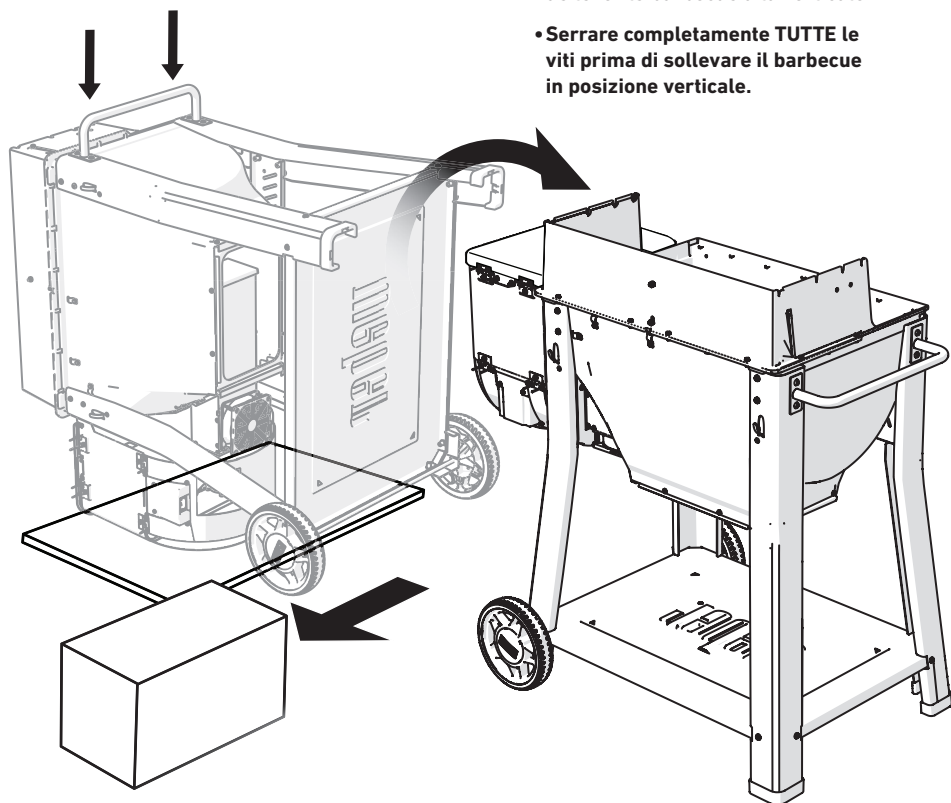

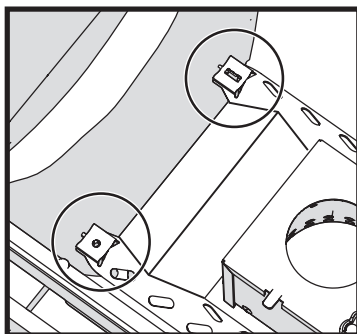
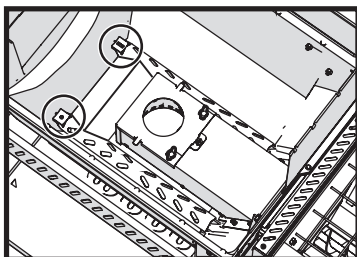
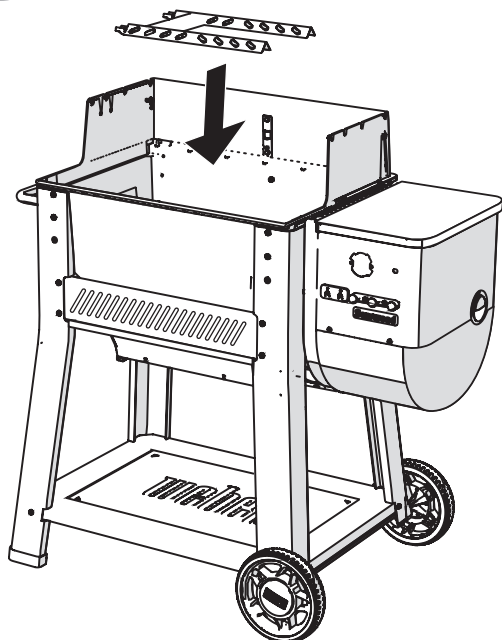
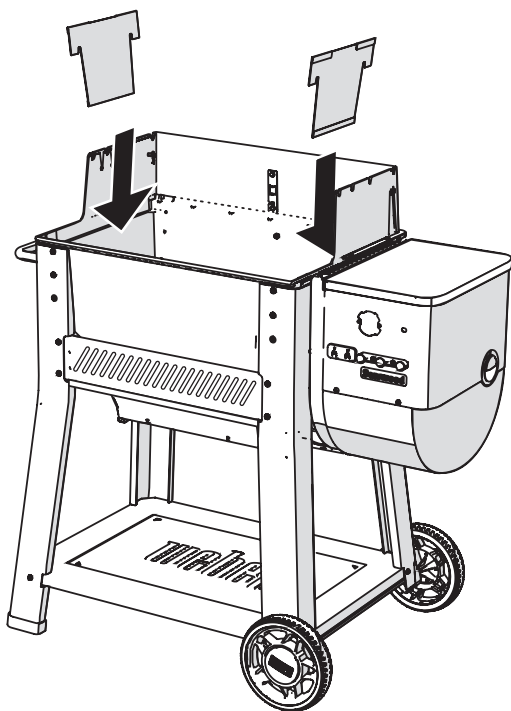
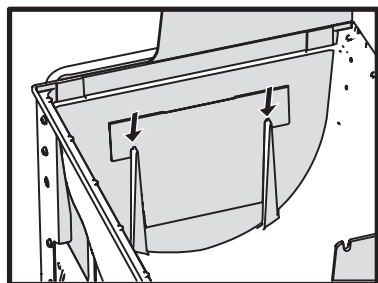

14

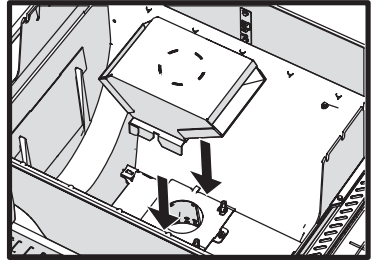
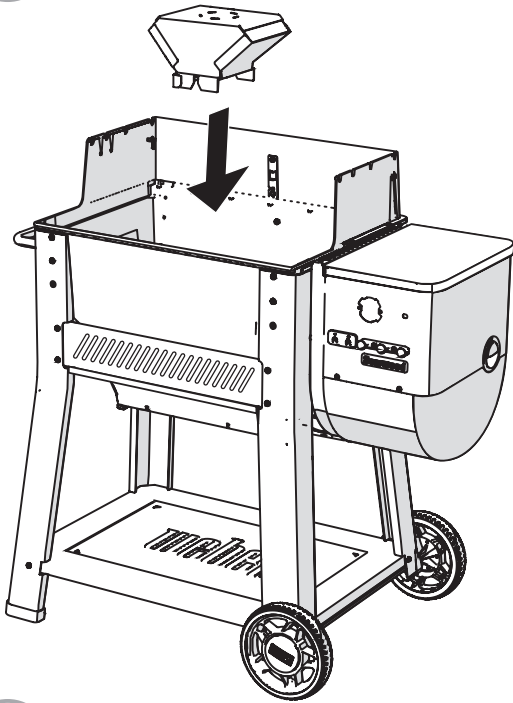

15

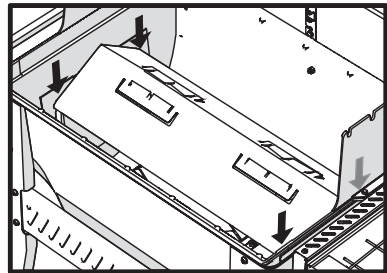
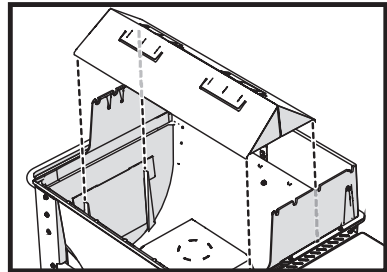
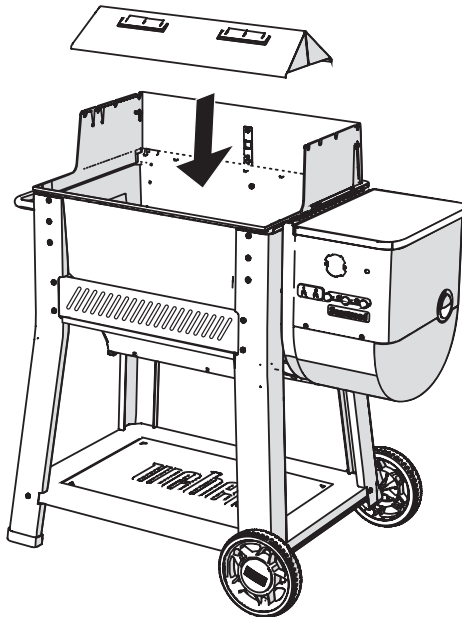

16

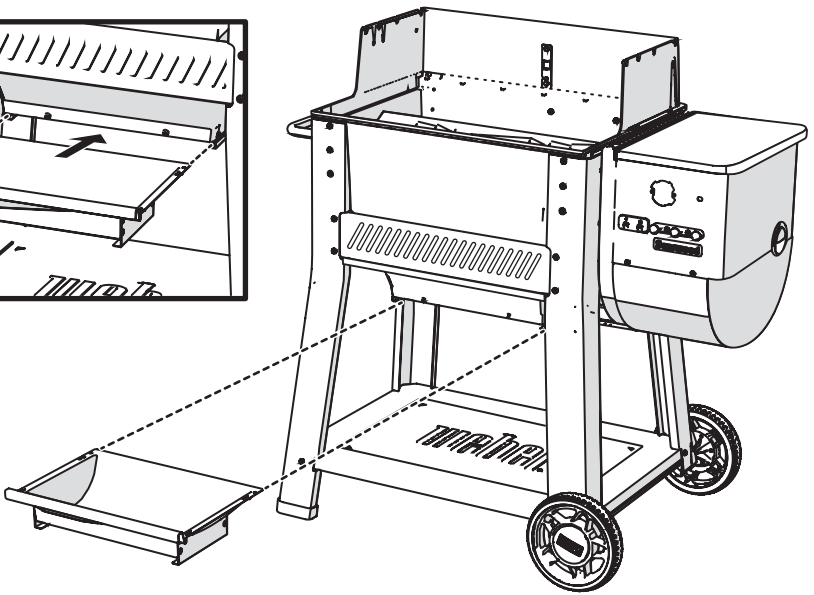
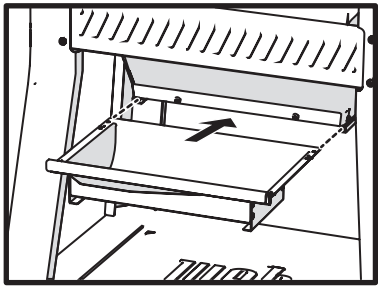

17

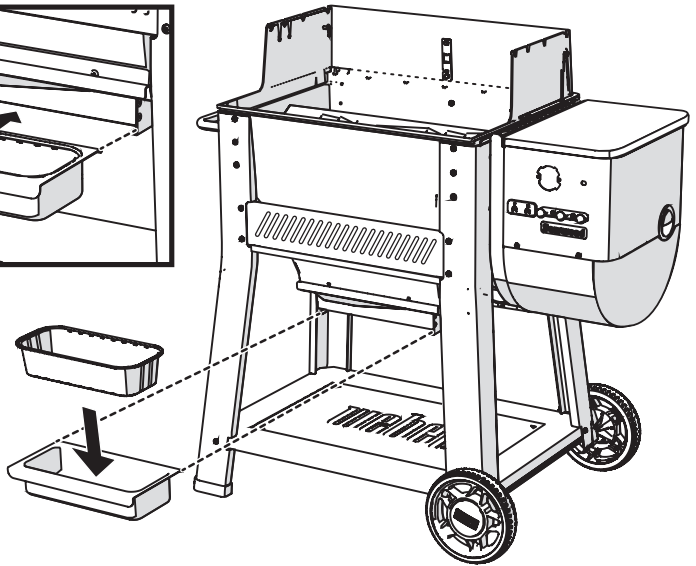
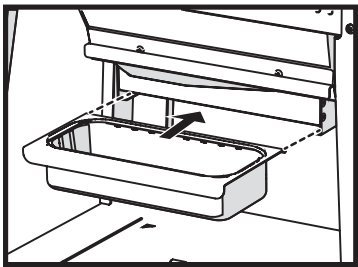

**18**

**Let op:** Voor deze montageslap zijn twee mensen nodig.

**Hinweis:** Für diesen Montageschritt werden zwei Personen benötigt.

**N. B. :** cette étape du montage requiert deux personnes.

**Nota:** per questa fase di assemblaggio sono necessarie due persone.

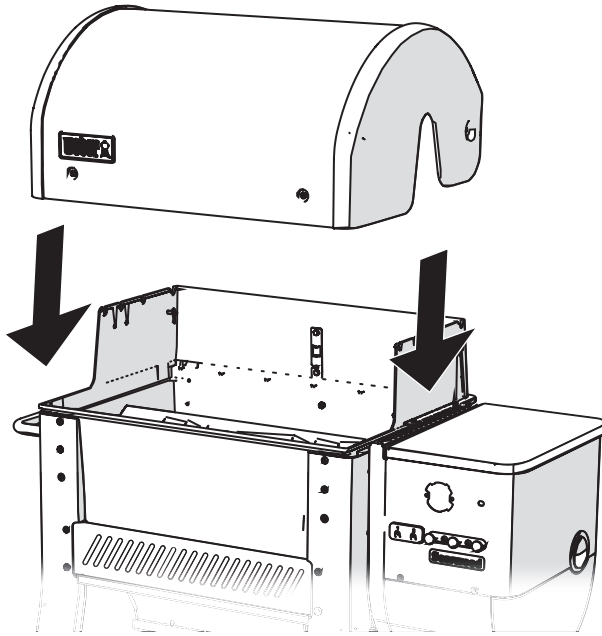
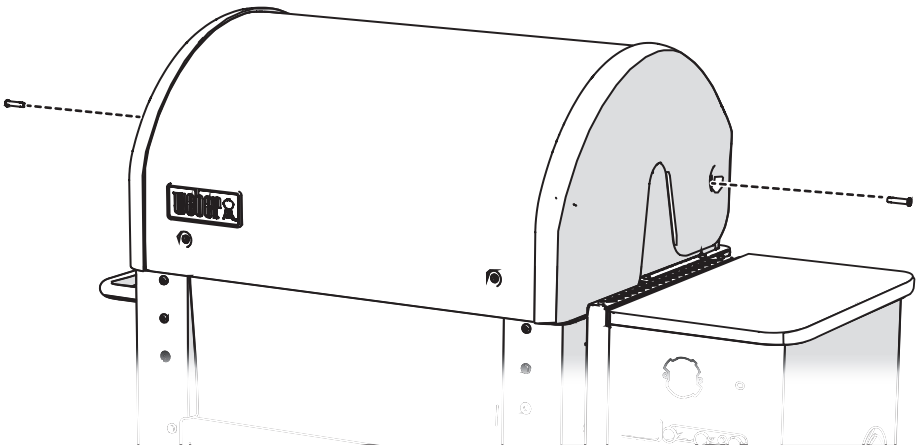
**19**

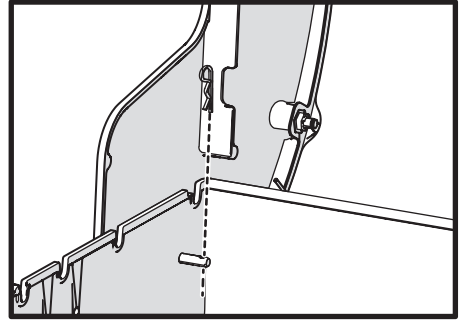
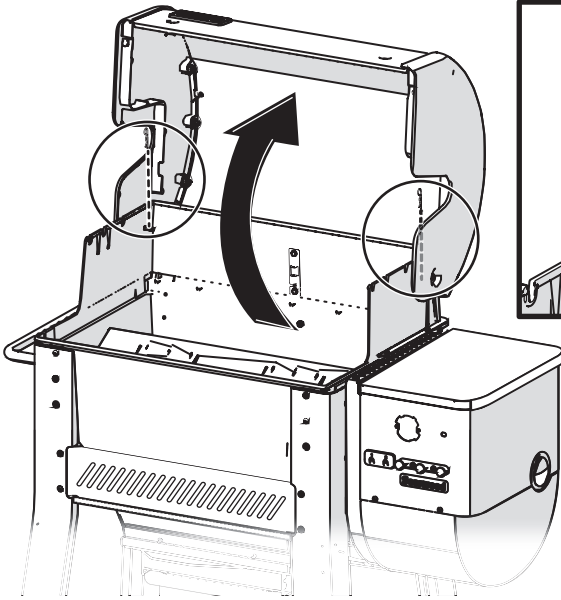

21

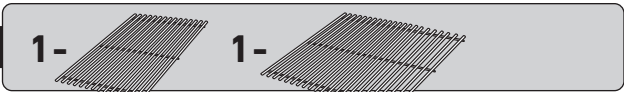

### SEARWOOD 600

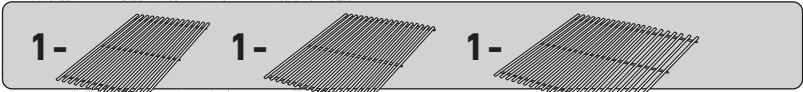
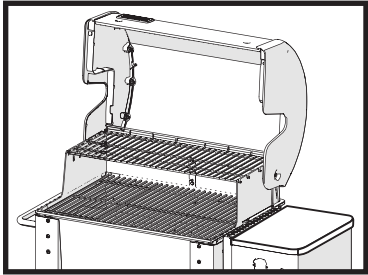
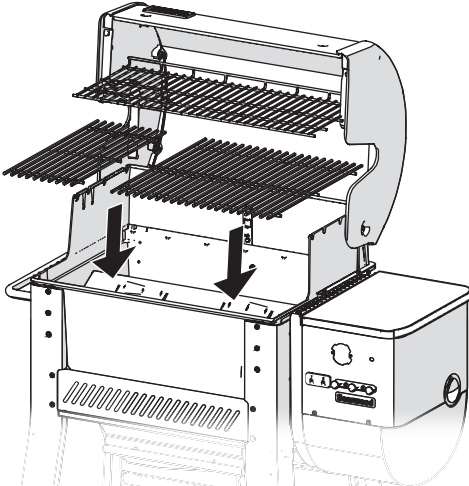

### SEARWOOD XL 600

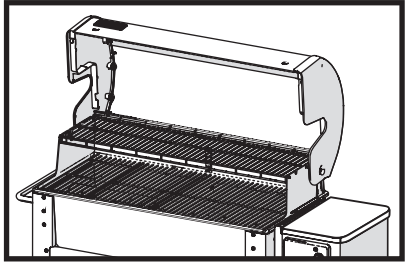
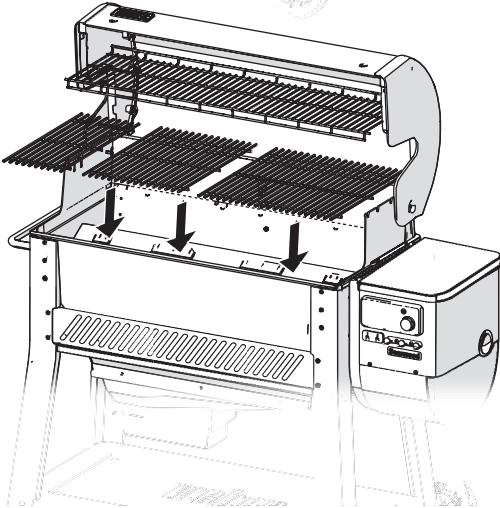

22

E 2-

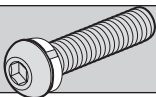

F 2-

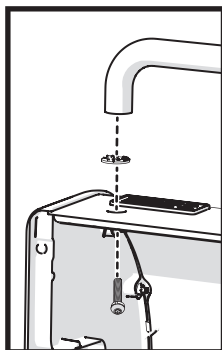
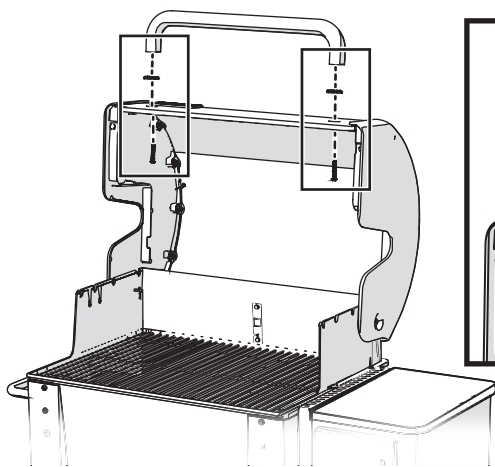

23

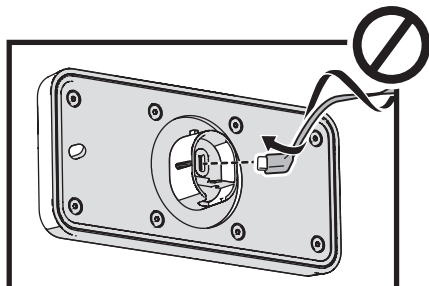
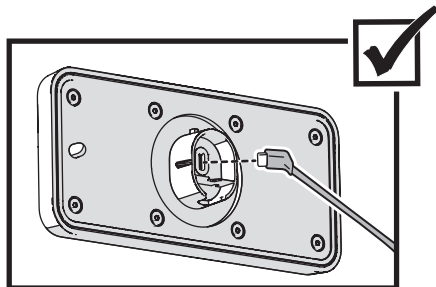
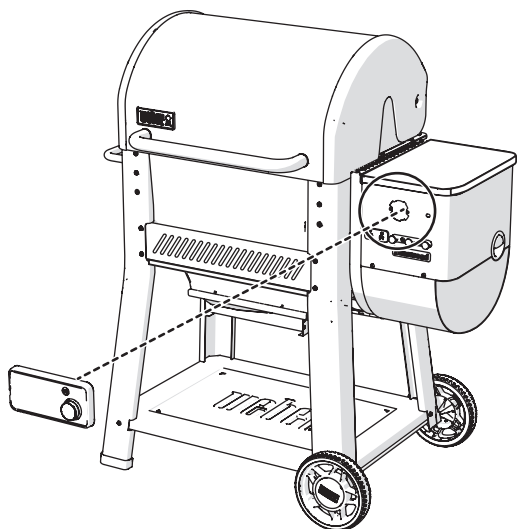

24

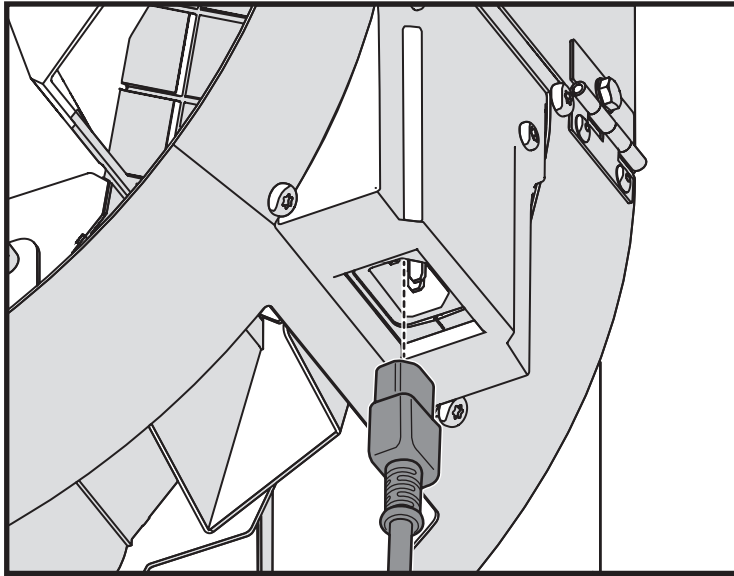

25

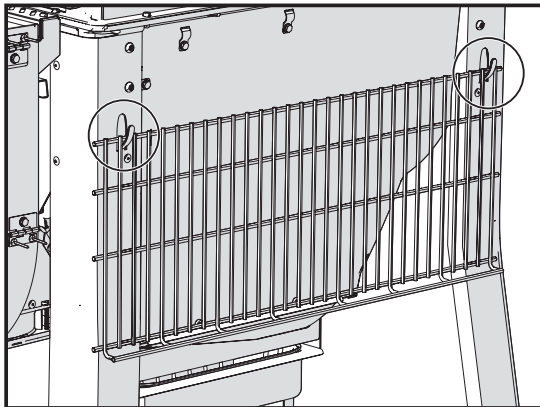

- Zorg ervoor dat alle onderdelen zijn gemonteerd en de schroeven volledig zijn aangedraaid voordat je de barbecue in gebruik neemt.
- Stelle sicher, dass alle Teile ordnungsgemäß zusammengebaut und sicher befestigt sind, bevor du den Grill in Betrieb nimmst.
- Assurez-vous que toutes les pièces sont assemblées et que toutes les fixations sont serrées avant de mettre votre barbecue en marche.
- Prima di utilizzare il barbecue, assicurarsi che tutte le parti siano assemblate e che la minuteria sia serrata.

**NL** Scan de QR-code om de WEBER CONNECT-app te downloaden.

Om je nieuwe WEBER CONNECT digitale lcd-controller volledig te activeren en updaten, moet je eerst de WEBER CONNECT-app downloaden.

**Downloaden, verbinding maken en registreren, en ontvang:**

- meldingen om gerechten te draaien en serveren
- tellers die aftellen totdat je eten gaar is
- Meldingen dat gerechten de gewenste gaarheid hebben bereikt
- Stapsgewijze barbecuehulp

**DE** Scanne den QR-Code, um die WEBER CONNECT App herunterzuladen.

Um deinen neuen digitalen WEBER CONNECT LCD-Regler vollständig zu aktivieren und zu aktualisieren, musst du zunächst die WEBER CONNECT App herunterladen.

**Nach dem Herunterladen, Verbinden und Registrieren erhältst du:**

- Benachrichtigungen zum Wenden und Servieren
- Garzeit-Countdowns
- Individuell anpassbare Benachrichtigungen zur Garstufe
- Schritt-für-Schritt-Hilfe beim Grillen

**FR** Scannez le code QR pour télécharger l'application WEBER CONNECT.

Pour activer et mettre à jour votre nouveau contrôleur numérique à écran LCD WEBER CONNECT, il est important de télécharger en premier l'application WEBER CONNECT.

**Téléchargez, connectez-vous et enregistrez-vous pour recevoir :**

- Des notifications pour retourner et servir les aliments
- Des comptes à rebours du temps de cuisson idéal
- Des alertes personnalisées de fin de cuisson
- Une assistance de cuisson au barbecue étape par étape

**IT** Scansiona il codice QR per scaricare l'app WEBER CONNECT.

Per attivare appieno e aggiornare il tuo nuovo controller digitale LCD WEBER CONNECT, è importante scaricare prima l'app WEBER CONNECT.

**Scarica, connettiti e registrati per ricevere:**

- Notifiche su quando rigirare e servire il cibo
- Timer di cottura
- Avvisi personalizzati sul grado di cottura
- Guida alla cottura passo passo



WEBER-STEPHEN PRODUCTS LLC  
www.weber.com

© 2024 Designed and engineered by Weber-Stephen Products LLC,  
1415 S. Roselle Road, Palatine, Illinois 60067 USA.